

**MODEL: LT100 - LINT TRAP**

The LT100 Lint Trap offers a simple and user-friendly solution for reducing maintenance associated with dryer exhaust ducts. The one-piece door with screen slides easily and firmly into place, without having to fuss with flimsy springs or clips. Its versatile design allows for either wall or ceiling mount installations.

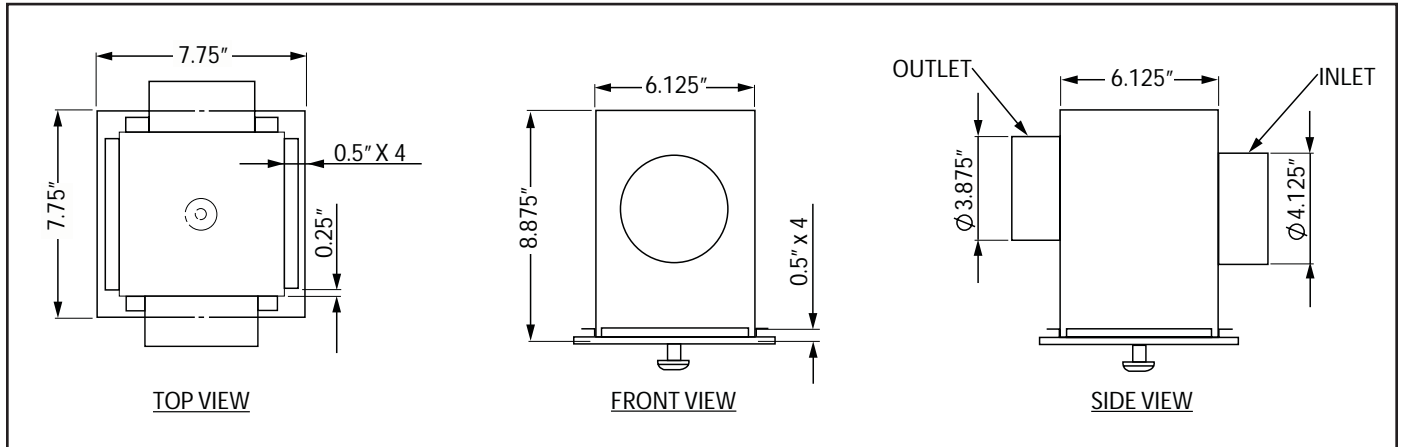

**CONSTRUCTION**

- 24 ga. corrosion-resistant, satin coat steel
- 9/16" mounting flange
- One piece door with integral screen
- Galvanized mesh filter
- Sturdy slide mechanism
- Rugged construction

**FEATURES & BENEFITS**

- Ceiling or wall mount option
- Mounts flush with drywall surface
- Can be painted to match décor
- Reduces lint build-up in duct
- Improves drying capacity
- Easy slide design is simple to use

PROJECT		ARCHITECT	
DATE		ENGINEER	
SUBMITTED BY		CONTRACTOR	
<b>SPECIFICATION</b>			
FAN NO.	MODEL NO.	QTY	OPTIONAL EQUIPMENT