

ECO-FLO ENERGY RECOVERY VENTILATOR

WHAT IS AN ECO-FLO ENERGY RECOVERY VENTILATOR?

The ECO-FLO Energy Recovery Ventilator (ERV) is the all-in-one ventilation solution for new construction and renovation projects. This compact unit is capable of exhausting stale indoor air and supplying fresh filtered air from outside. The ERV core extracts thermal energy from the exhausted air and uses it to either pre-heat or pre-cool the incoming supply air (depending on the season). The ECO-FLO ERV has the added benefit of indoor humidity control, making it ideal for use in both living and working environments.



FEATURES & BENEFITS

- Extracts stale indoor air
- Recovers thermal energy from extracted air
- Supplies fresh, pre-treated air
- Maintains a comfortable humidity setting
- Moisture damage prevention
- Lowers heating and cooling costs throughout the year
- Low energy demand (7 W)
- Quiet operation (as low as 0.2 SONES)
- Multifunctional wireless remote control
- Plug-&-Play installation
- Air purification (MERV 5)
- Rated for continuous operation

ERV VS. HRV: WHAT'S THE DIFFERENCE?

An HRV is designed to supply fresh air to a home, and exhaust stale air from the home. The core of an HRV stores heat from the stale exhaust air in winter, and pre-heats the incoming supply air. In the summer, the core is effectively chilled by the exhausted air, and it pre-cools the incoming supply air.

- Suitable in colder climates where there is excess humidity during the heating season.

An ERV does everything that an HRV does. In addition, an ERV allows some of the moisture in the more humid air stream to be transferred to the air stream that is dryer. This limits the amount of moisture that is expelled in the winter and that enters during the summer.

- Suitable for colder climates with no excess humidity during the heating season, as well as for warmer climates with high outdoor humidity in the cooling season.

SELECTION

The criteria to be considered when designing a ventilation network are regional climate and square footage of the building. The climate is the deciding factor whether an ERV or an HRV will be more effective, while the square footage determines how many ventilators will be required.

ECO-FLO ENERGY RECOVERY VENTILATOR

APPLICATIONS

- **New construction**
- **Renovation projects**
- **Commercial buildings**
- **Offices**
- **Homes**
- **Apartments**

A single ECO-FLO ERV can ventilate rooms up to 500 square feet. The fan speed and humidity settings allow for personalized control of each individual room. This makes an ERV suitable for both living and working environments.

Multiple ventilators can operate independently of each other, or they can be wired for primary-secondary operation.

Ventilators can be programmed to operate in unison (the same mode) or in complementary modes (supply and extract). It is recommended that paired units be used to ensure balanced ventilation.

Multiple ECO-FLO ventilators can provide an easy, cost-effective solution for larger buildings undergoing construction or renovation. When arranging a ventilation network, install one unit in each room. For larger rooms, install two or more ventilators. Air flows from one room to another through doors, openings, or hallways, and ensures constant circulation.

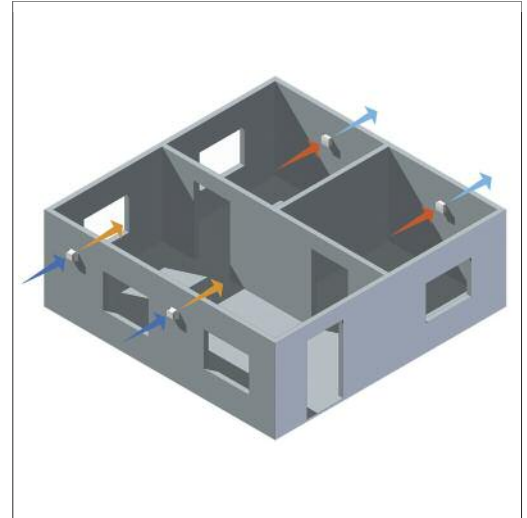

OPERATION MODES

1. Natural Airflow



- Shutter is open; fan does not run.
- Air flows freely through ventilator and is purified by filters.

2. Supply Mode



- Ventilator continuously draws in fresh air from outside.
- Air is purified by the filters.

3. Ventilation Mode



- Ventilator operates in permanent supply or extract mode.
- Synchronized units can provide balanced ventilation.

4. Regeneration Mode



- Ventilator alternates between supply and exhaust every 70 seconds.
- Thermal energy is recovered, and the humidity setting is maintained.

Cycle I.

Warm stale air is extracted from the room. It heats and moisturizes the ERV core, transferring up to 88% of thermal energy. In 70 seconds, the ventilator switches to supply mode.

Cycle II.

Fresh outside air flows through the ventilator, absorbing the accumulated moisture and thermal energy in the ERV core and supplying warmed air into the room. In 70 seconds, the ventilator switches back to extraction mode.

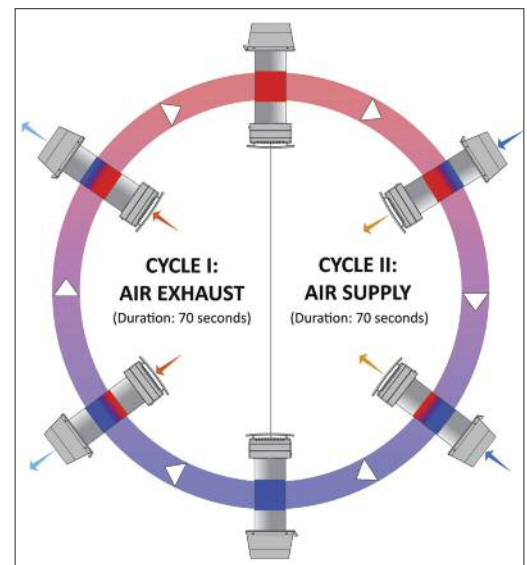

ECO-FLO ENERGY RECOVERY VENTILATOR

CONSTRUCTION

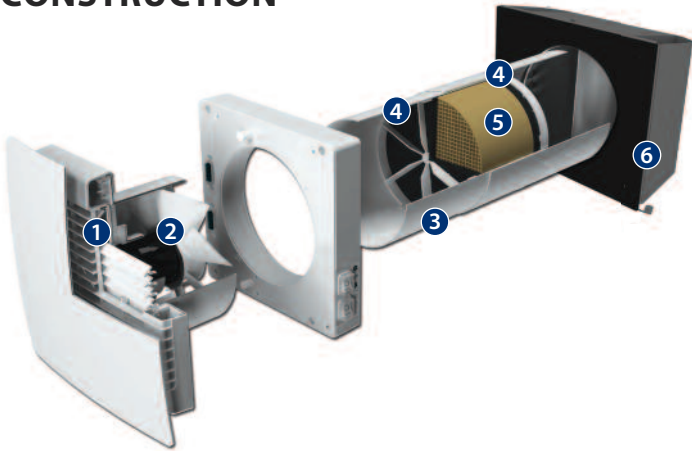

1. Front Grille with Automatic Shutter
 - Easy access for filter cleaning or replacement
 - Made of high quality snow-white ABS plastic
2. Reversible Axial Fan
 - Reversible DC ball bearing motor
 - Integrated overheating protection
3. Telescopic Duct
 - 6" diameter
 - Suitable for walls of varying thickness
4. Air Filters (MERV 5)
 - Two filters provide air free of dust & pollen
 - Filters are washable for easy maintenance
5. ERV Core
 - Recovery efficiency of 88% @32 F
 - Anti-bacterial treatment
6. Exterior-Mounted Hood
 - Stainless steel
 - Corrosion proof

VENTILATION CONTROLS

The ventilator is operated with the wireless remote control or the buttons on the ventilator's casing.

REMOTE CONTROL

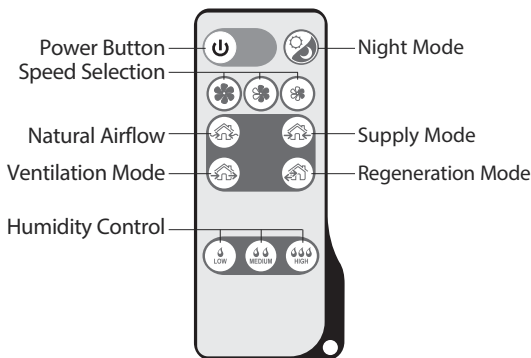

VENTILATOR CONTROL

SPEED SELECTION SWITCH

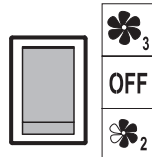

High Speed (3) - Ventilator operates at maximum air capacity.

OFF - Ventilator does not operate. Shutter is closed.

Medium Speed (2) - Ventilator operates at 50% air capacity.

OPERATION MODE SWITCH

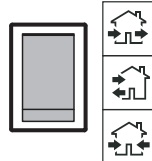

Ventilation Mode - Ventilators operate in either extract or supply mode, depending on CN7 jumper position.

Regeneration Mode - Ventilators switch every 70 seconds between supply and extraction, providing heat regeneration and humidity control.

Supply Mode - Ventilators operate in supply mode, irrespective of CN7 jumper position.

SPECIFICATIONS

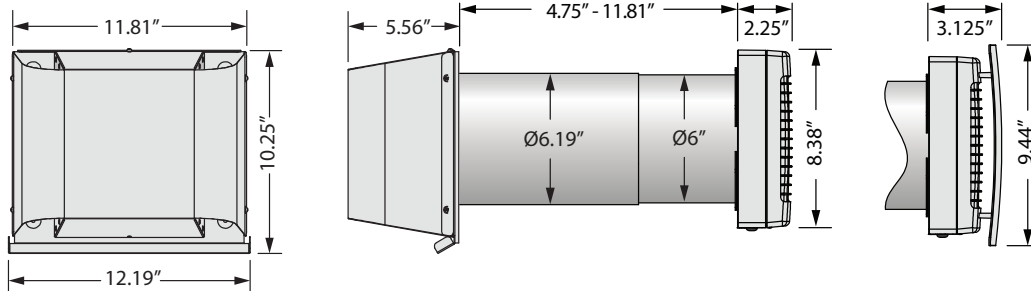

MODEL	MANUFACTURE CODE	THERMAL RECOVERY	PERFORMANCE						TRANSPORTED AIR TEMP. (F)	POWER SUPPLY
			SPEED	RPM	SONES @ 3M	WATTS	AMPS	CFM		
ECO-FLO	RA1-50-2	88%	Low	610	0.2	4.50	0.024	12	From -4 up to 104	120 V 60 Hz 1 Phase
			Med	800	0.4	5.00	0.026	21		
			High	1450	0.5	7.00	0.039	30		

IP24 protection

ECO-FLO ENERGY RECOVERY VENTILATOR

INSTALLATION

The ventilator is designed for through-the-wall installation in a few easy steps. The telescopic design enables installation in walls with thickness ranging from 4.75" to 11.81".

1. Prepare a round through hole in the outer wall. Install the telescopic duct inside the wall, center the air duct using the mounting plate, and seal it with mounting foam.

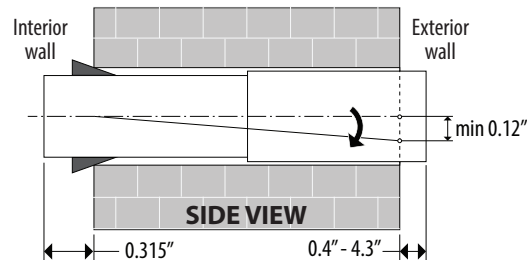
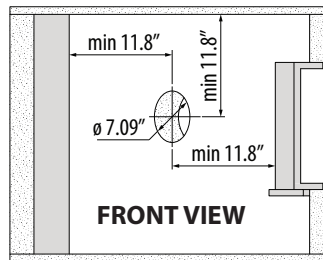

2. Install the mounting plate to the wall. Consecutively install the airflow straightener, filter, ERV core, second filter, and second airflow straightener. Attach the ventilation unit to the mounting plate.

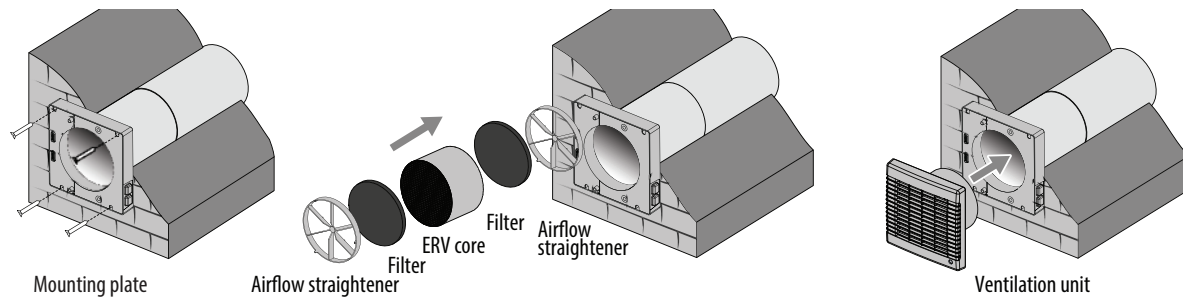

3. Disassemble the exterior-mounted hood to enable access to the fastening holes. Fix the back of the exterior-mounted hood on the wall. Install the front of the exterior-mounted hood.

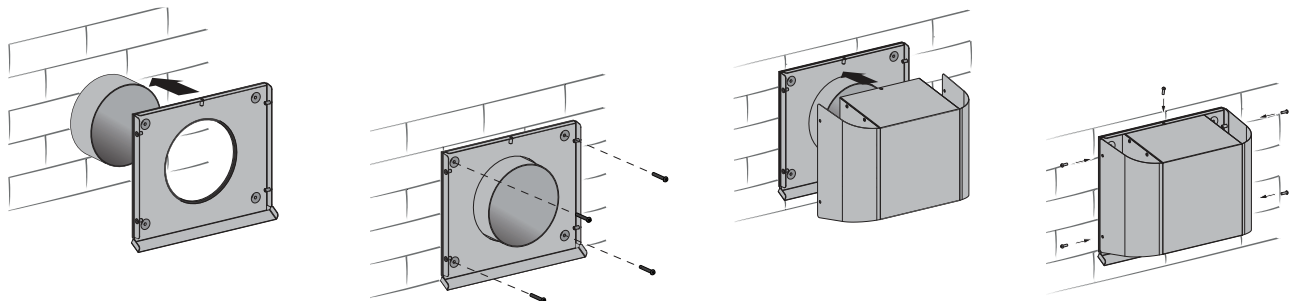

The illustrations shown above are for information purposes only. Refer to ECO-FLO Installation & Maintenance manual for complete installation instructions.