

better AIRFLOW by DESIGN™

MODEL: TF TRANQUIL BATHROOM FANS

TF Tranquil bathroom fans offer whisper-quiet exhaust (under 1 sone). The built-in damper prevents a backdraft, keeping tempered air in a home when the fan is not operating.

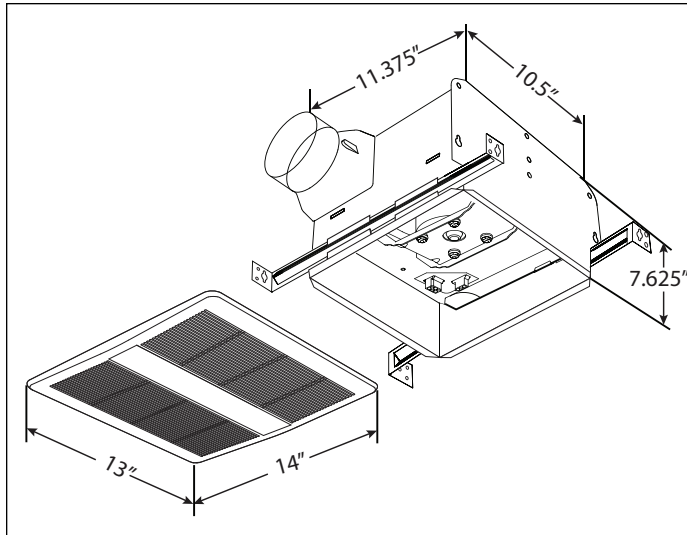

| Model | TF80 | TF110 |
|-----------------------------|--------------|--------------|
| Air Volume (cfm @ 0.1" SP) | 80 | 110 |
| Air Volume (cfm @ 0.25" SP) | 58 | 100 |
| Noise (Sones) | 0.4 | 0.9 |
| Power Consumption (W) | 25 | 33 |
| Power Rating (V/Hz) | 120V / 60 Hz | 120V / 60 Hz |
| Duct Diameter (In.) | 4 & 6 | 4 & 6 |



HVI & Energy Star for Model TF80 only

CONSTRUCTION

- Galvanized steel housing
- Clean, simple grille design
- Double hanger mounting brackets adjust to 24" span
- Built-in backdraft damper
- Available to fit duct sizes 4" & 6"
- TF110 is HVI certified and Energy Star qualified for 6" duct only

MOTOR

- Efficient AC motor
- Single phase
- 120V, 60 Hz
- Automatic reset thermal overload protection

| PROJECT | | | | ARCHITECT | | | |
|---------------|-----------|-----|-------|------------|------|-----|--------------------|
| DATE | | | | ENGINEER | | | |
| SUBMITTED BY | | | | CONTRACTOR | | | |
| SPECIFICATION | | | | | | | |
| FAN NO. | MODEL NO. | CFM | VOLTS | WATTS | AMPS | QTY | OPTIONAL EQUIPMENT |
| | | | | | | | |
| | | | | | | | |
| | | | | | | | |
| | | | | | | | |
| | | | | | | | |
| | | | | | | | |