

4 THREADED HOLES FOR U MOUNTING
BOLTS EQUALLY SPACED ABOUT M
BOLT CIRCLE DIAMETER.

4 x 0.2 DIAMETER HOLES
EQUALLY SPACED ABOUT
H DIAMETER

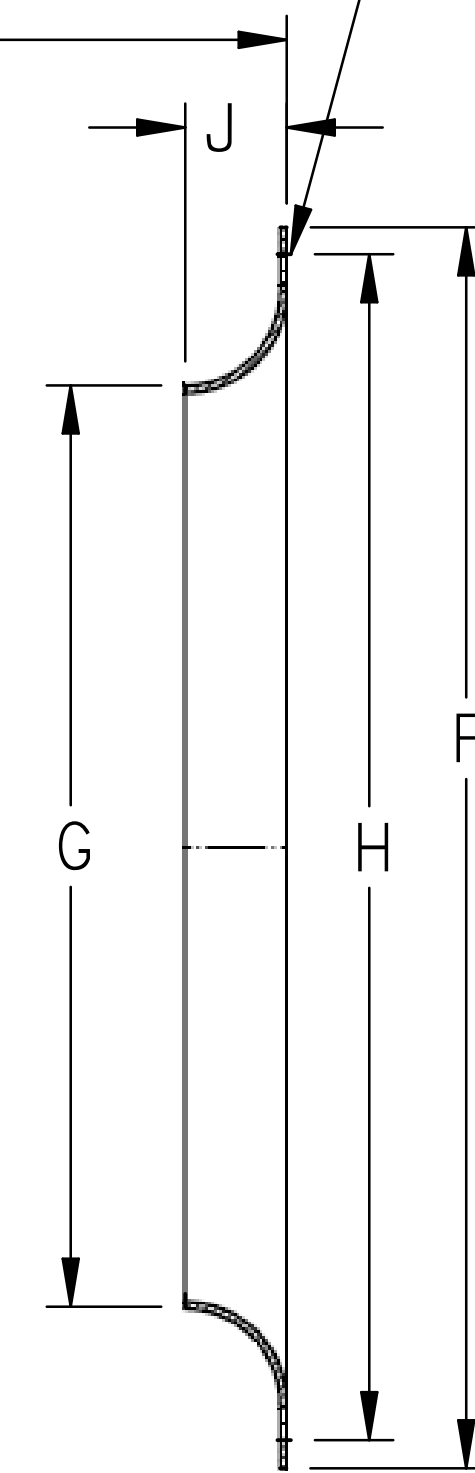
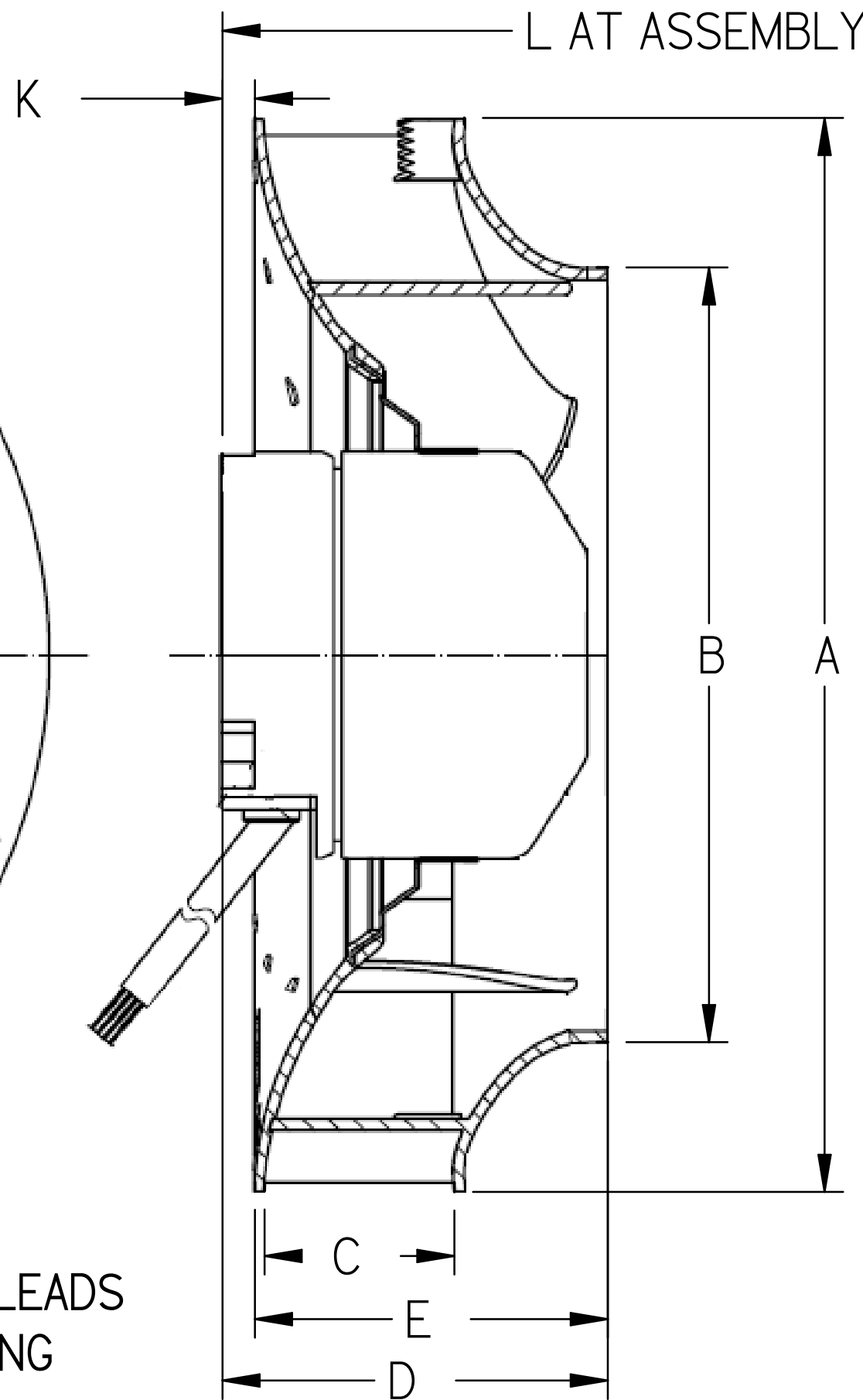
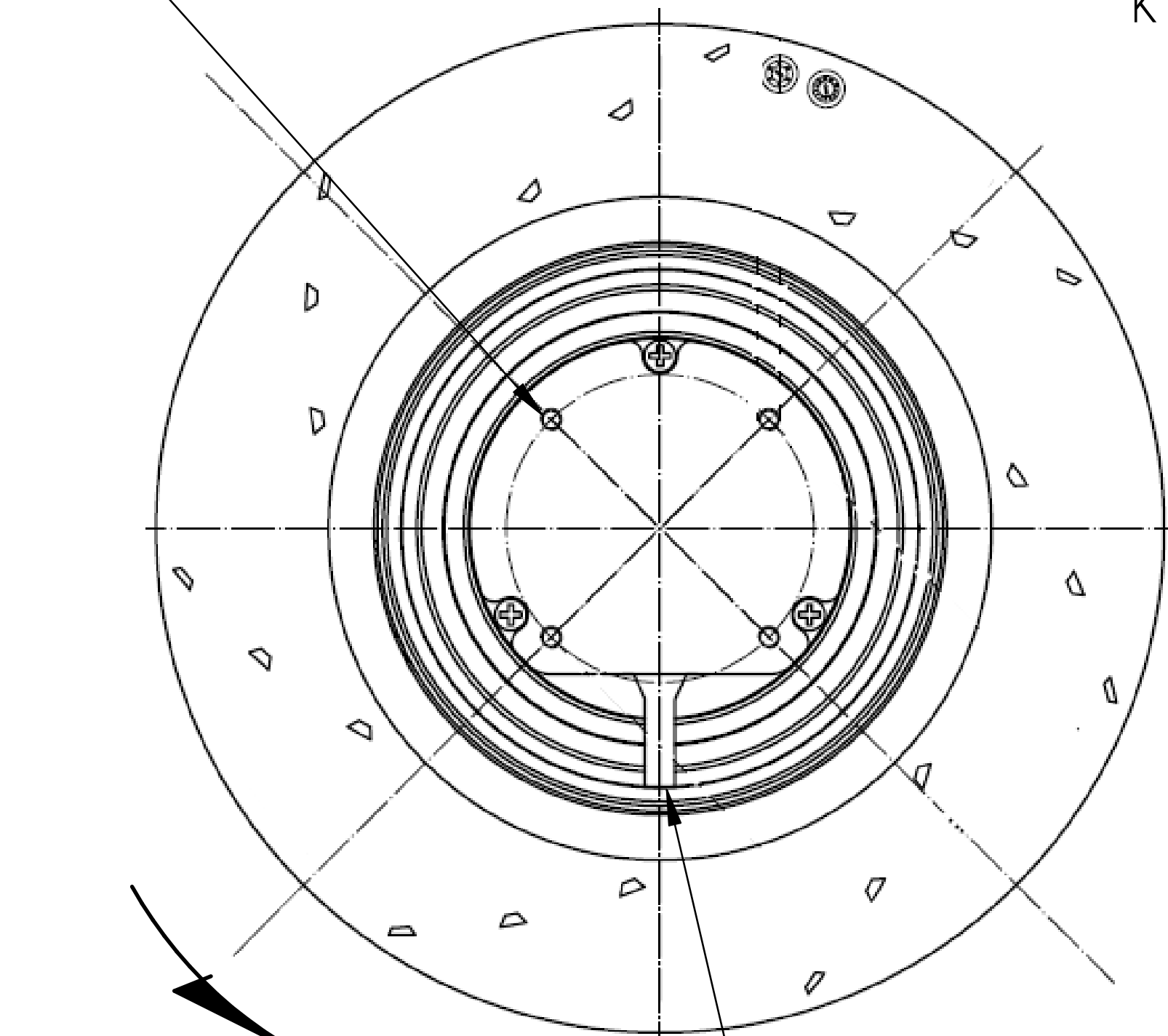

ROTATION

DIMENSIONS IN INCHES
UNLESS OTHERWISE NOTED

ELECTRICAL LEADS
APPROX X LONG

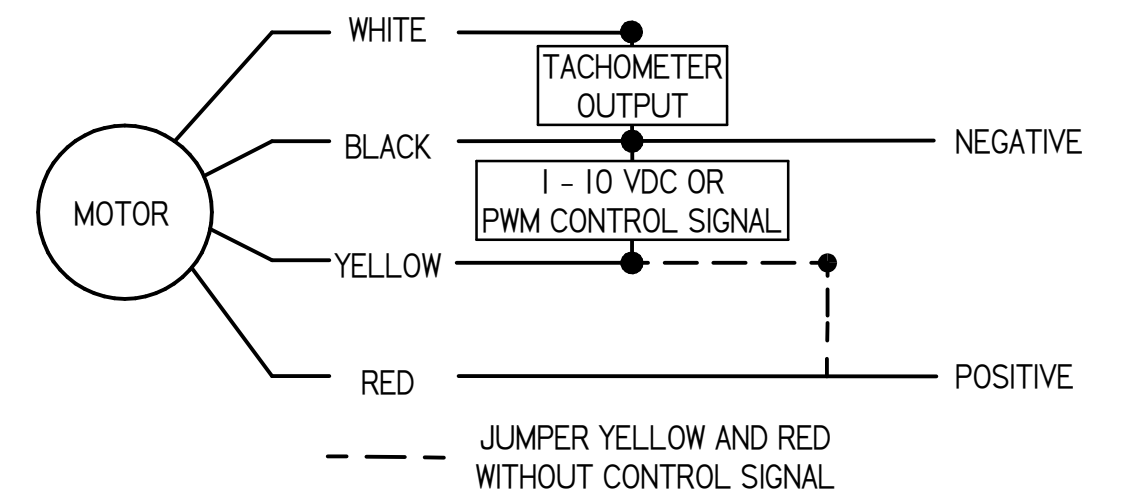

MOTOR WIRING DIAGRAM

MODEL	DIMENSIONS (IN INCHES)															
	A	B	C	D	E	F	G	H	J	K	L	M	U	V	X	
DC190-2B34	7.4	5.2	1.3	2.7	2.5	6.7	4.9	6.2	0.6	0.2	3.2	2.3	M4 x 6	4.0	17.7	
DC220-2B42	8.7	6.3	1.7	2.8	2.5	10.0	6.0	9.7	0.8	0.3	4.0	2.3	M4 x 6	4.0	17.7	
DC225-2B65	8.9	6.0	2.5	3.9	3.6	8.8	5.7	8.3	1.1	0.3	4.9	2.3	M4 x 6	4.0	17.7	
DC250-2B61	9.8	6.8	2.4	3.9	3.6	10.0	6.4	9.4	1.2	0.3	5.0	2.3	M4 x 6	4.0	17.7	
DC280-2B82	11.1	7.5	3.2	5.3	4.4	11.8	6.9	11.5	1.2	1.0	6.4	2.3	M4 x 6	6.0	17.7	
DC315-2B50	12.4	8.5	2.0	3.9	3.4	13.8	8.2	13.4	1.2	0.5	5.0	2.3	M4 x 6	6.0	17.7	
DC355-2B97	14.0	9.7	3.8	6.2	5.6	13.8	9.4	12.8	1.2	0.6	7.3	3.5	M5 x 9	6.0	39.4	
DC400-2B93	15.9	10.6	3.6	6.3	5.6	14.5	10.1	13.5	1.4	0.7	7.6	3.5	M5 x 9	6.0	39.4	

DIMENSIONS SUBJECT TO CHANGE WITHOUT NOTICE.
DRAWING NOT TO BE USED FOR CONSTRUCTION.

 <p>Better Airflow By Design</p>							
				DC GENERAL SUBMITTAL			
				DC MOTORIZED IMPELLER			
REV.	DATE	BY	J. M. EVANS 16 AUG 2016 DC General Submittal				