

# TF TRANQUIL BATHROOM FANS - LOW PROFILE

The low profile design of the TF-N Tranquil Bathroom Fan accommodates space constraints and fits in a wall or ceiling. The built-in damper prevents a backdraft, keeping tempered air in a home when the fan is not operating.

## FEATURES & BENEFITS

- Whisper-quiet bathroom fan
- Low-profile, 3-3/8" depth housing
- May be mounted in a wall or ceiling
- Clean, simple grille design
- Galvanized steel housing
- Easy installation
- Built-in backdraft damper
- Efficient AC motor
- 120V, 60 Hz operation
- Automatic reset thermal overload protection
- Fits 4" oval duct

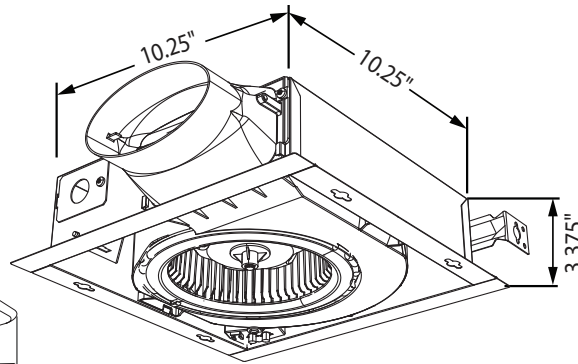
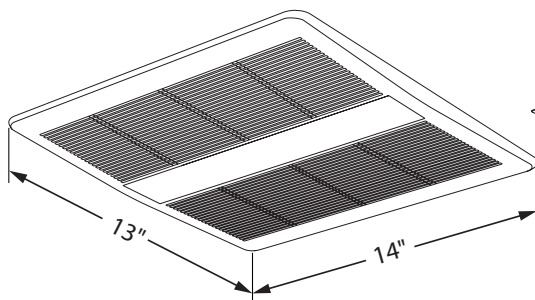

MODEL	MANUFACTURE CODE	PERFORMANCE			POWER SUPPLY
		CFM 0.1" SP	SONES	WATTS	
TF80N	SES80	80	0.7	17.3	120 V 60 Hz
TF100N	SES100	100	1.5	24.6	1 Phase

MODEL	DIMENSIONS IN INCHES*					
	DUCT DIA.	GRILLE SIZE	HOUSING SIZE			WT LBS
	L	W	H			
TF80N	4	13 x 14	10.25	10.25	3.375	5.0
TF100N						

\*DO NOT USE FOR CONSTRUCTION CONSULT FACTORY FOR CERTIFIED PRINTS

