

AFK-ECM FLANGE FANS

FEATURES & BENEFITS

- Ideal for maximum savings on variable speed applications
- IE5 efficiency, electronically commutated (EC) motors
- Plug-and-play integrated motor and drive
- Bluetooth communication and programming software available
- 1 to 10 HP motors available for 50/60Hz supply
- Single phase 110-115V or 200-240V; 3-phase 200-240V or 380-480V
- Supply, exhaust or fully reversible configurations
- Cast aluminum, airfoil aluminum impellers as standard, optional GRP available
- Heavy gauge steel construction with baked polyester finish
- Customizable for OEM applications or new construction
- Sizes range from 12" to 42"; capacities up to 40,000 cfm



APPLICATIONS

- General ventilation
- Industrial drying
- Renewable energy
- OEM cabinet cooling
- Variable speed AHUs
- Circulation / recirculation units

ACCESSORIES / OPTIONS

- Special coatings
- Special materials
- Mounting panel
- Motor side guard
- Impeller side guard
- Reverse flow construction
- Housing yoke with mounting bracket
- Axial- or top-mount drive up to 7.5 HP motors
- Top-mount drive for 10 HP motors

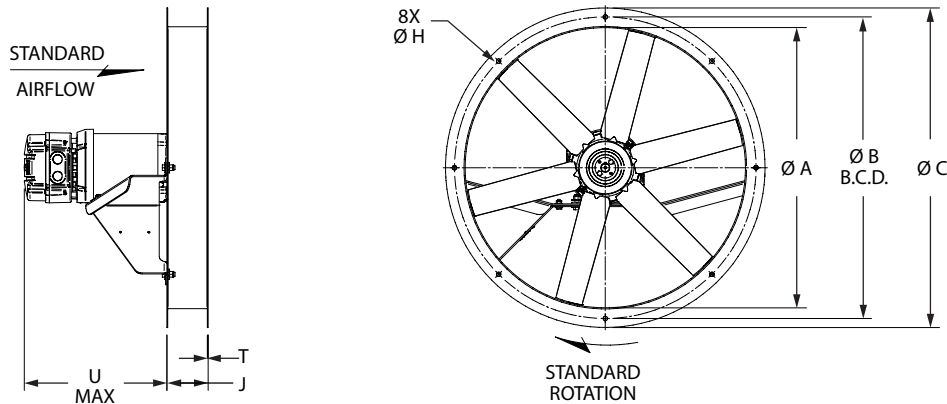

DIMENSIONS IN INCHES*

MODEL	A	B	C	H	J	T	U MAX	MAX MTR FRAME
AFK-12-ECM	12.2	13.8	15.0	0.44	3.0	0.06	14.5	143/5T
AFK-14-ECM	14.2	16.3	17.5	0.44	3.0	0.06	14.5	143/5T
AFK-16-ECM	16.2	18.0	19.5	0.44	4.0	0.08	14.5	143/5T
AFK-18-ECM	18.2	20.8	22.0	0.44	4.0	0.08	14.5	143/5T
AFK-21-ECM	21.2	23.3	24.5	0.44	4.0	0.08	14.5	143/5T
AFK-24-ECM	24.2	26.3	27.5	0.44	4.0	0.08	19.5	182/4T
AFK-27-ECM	27.2	29.3	31.0	0.44	4.0	0.08	19.5	182/4T
AFK-30-ECM	30.2	32.6	34.5	0.56	4.0	0.11	20.5	213/5T
AFK-36-ECM	36.2	38.4	40.5	0.56	5.0	0.11	20.5	213/5T
AFK-42-ECM	42.2	44.6	46.5	0.56	5.0	0.11	15.9 (top drive)	213/5T

*DO NOT USE FOR CONSTRUCTION

CONSULT FACTORY FOR CERTIFIED PRINTS