

ROOF VENTILATORS

UDVL DIRECT DRIVE UPBLAST ROOF VENTILATORS

FEATURES & BENEFITS

- Low silhouette weatherproof closure for vertical air discharge
- Direct drive, low maintenance
- Spark resistant, cast aluminum airfoil axial impeller
- Factory set adjustable pitch impeller
- Aerodynamically efficient performance
- TEFC industrial duty motor
- Weather-tight steel curb panel
- Heavy duty welded steel construction
- Baked polyester powder coat finish with a zinc rich primer
- Rugged galvanized damper section with butterfly damper blades
- Damper rods turn in nylon bearings and require no lubrication



APPLICATIONS

- General ventilation
- Exhaust or smoke fumes

ACCESSORIES / OPTIONS

- Pre-fabricated roof curbs
- Explosion proof & special duty motors
- Hot dipped galvanized construction
- 304 or 316 stainless steel construction
- Disconnect switches, mounted or mounted & wired
- Magnetic damper pads for positive closure
- Baked epoxy powder coat finish, two layers
- AMCA spark resistant construction - consult factory

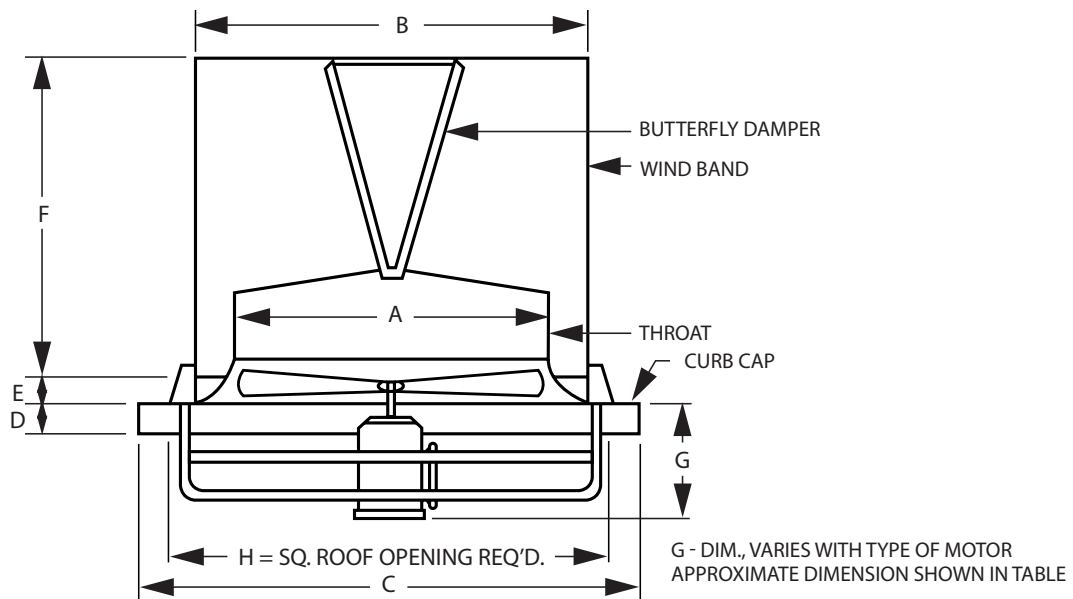

| MODEL | DIMENSIONS IN INCHES* | | | | | | | | WT (lbs) LESS MTR | MAX MTR FRAME |
|---------|-----------------------|----|--------|-----|---|----|----|----|----------------------|------------------|
| | A | B | C | D | E | F | G | H | | |
| UDVL-18 | 19 | 24 | 33 SQ. | 2.5 | 3 | 16 | 13 | 28 | 150 | 145T |
| UDVL-24 | 25 | 30 | 39 SQ. | 2.5 | 3 | 19 | 15 | 34 | 213 | 184T |
| UDVL-30 | 31 | 36 | 45 SQ. | 2.5 | 3 | 22 | 15 | 40 | 255 | 184T |
| UDVL-36 | 37 | 42 | 51 SQ. | 2.5 | 3 | 25 | 18 | 46 | 305 | 215T |
| UDVL-42 | 43 | 48 | 57 SQ. | 2.5 | 3 | 27 | 18 | 52 | 295 | 256T |
| UDVL-48 | 49 | 54 | 63 SQ. | 2.5 | 3 | 30 | 20 | 58 | 490 | 256T |
| UDVL-60 | 61 | 66 | 75 SQ. | 2.5 | 3 | 42 | 22 | 70 | 615 | 256T |

*DO NOT USE FOR CONSTRUCTION

CONSULT FACTORY FOR CERTIFIED PRINTS

| MODEL | AIRFLOW PERFORMANCE (CFM) | |
|---------|---------------------------|---------|
| | MINIMUM | MAXIMUM |
| UDVL-18 | 2,650 | 4,600 |
| UDVL-24 | 4,715 | 10,500 |
| UDVL-30 | 7,365 | 17,750 |
| UDVL-36 | 10,605 | 22,600 |
| UDVL-42 | 14,435 | 28,970 |
| UDVL-48 | 18,765 | 41,000 |
| UDVL-60 | 29,445 | 54,000 |

MINIMUM CFM VALUE REQUIRED TO OPEN DAMPER BLADES

UBVL BELT DRIVE UPBLAST ROOF VENTILATORS

FEATURES & BENEFITS

- Low silhouette weatherproof closure for vertical air discharge
- V-belt drive for low speed operation
- Spark resistant, cast aluminum airfoil axial impeller
- Factory set adjustable pitch impeller
- Aerodynamically efficient performance
- TEFC industrial duty motor
- Self-aligning pillow block ball bearings
- Weather-tight steel curb panel
- Heavy duty welded steel construction
- Baked polyester powder coat finish with a zinc rich primer
- Rugged galvanized damper section with butterfly damper blades
- Damper rods turn in nylon bearings and require no lubrication



APPLICATIONS

- General ventilation
- Exhaust or smoke fumes

ACCESSORIES / OPTIONS

- Pre-fabricated roof curbs
- Explosion proof & special duty motors
- Hot dipped galvanized construction
- 304 or 316 stainless steel construction
- Disconnect switches, mounted or mounted & wired
- Magnetic damper pads for positive closure
- Baked epoxy powder coat finish, two layers
- AMCA spark resistant construction - consult factory

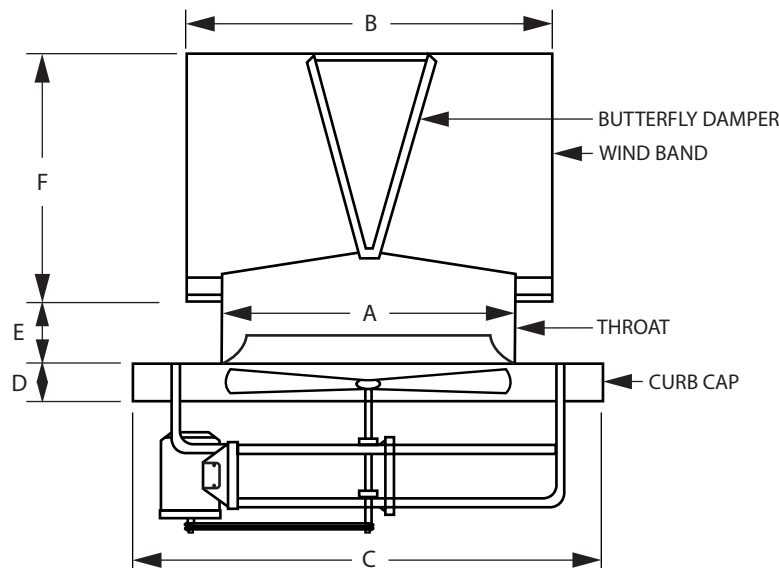

| MODEL | DIMENSIONS IN INCHES* | | | | | | WT (lbs) LESS MTR | MAX MTR FRAME |
|---------|-----------------------|----|--------|-----|---|----|----------------------|------------------|
| | A | B | C | D | E | F | | |
| UBVL-24 | 25 | 30 | 39 SQ. | 2.5 | 3 | 19 | 270 | 145T |
| UBVL-30 | 31 | 36 | 45 SQ. | 2.5 | 3 | 22 | 330 | 145T |
| UBVL-36 | 37 | 42 | 51 SQ. | 2.5 | 3 | 25 | 350 | 145T |
| UBVL-42 | 43 | 48 | 57 SQ. | 2.5 | 3 | 27 | 413 | 184T |
| UBVL-48 | 49 | 54 | 63 SQ. | 2.5 | 3 | 30 | 478 | 184T |
| UBVL-54 | 55 | 60 | 69 SQ. | 2.5 | 3 | 36 | 830 | 184T |
| UBVL-60 | 61 | 66 | 75 SQ. | 2.5 | 3 | 42 | 895 | 184T |

*DO NOT USE FOR CONSTRUCTION

CONSULT FACTORY FOR CERTIFIED PRINTS

| MODEL | AIRFLOW PERFORMANCE (CFM) | |
|---------|---------------------------|---------|
| | MINIMUM | MAXIMUM |
| UBVL-24 | 4,715 | 7,090 |
| UBVL-30 | 7,365 | 12,473 |
| UBVL-36 | 10,605 | 16,554 |
| UBVL-42 | 14,435 | 23,645 |
| UBVL-48 | 18,765 | 33,160 |
| UBVL-54 | 23,850 | 37,458 |
| UBVL-60 | 29,445 | 44,600 |

MINIMUM CFM VALUE REQUIRED TO OPEN DAMPER BLADES

ROOF VENTILATORS

UBV BELT DRIVE UPBLAST ROOF VENTILATORS

FEATURES & BENEFITS

- Standard upblast weatherproof closure for vertical air discharge
- V-belt drive for low speed operation
- Spark resistant, cast aluminum airfoil axial impeller
- Factory set adjustable pitch impeller
- TEFC motor located outside of airstream
- Adjustable motor base with self-aligning pillow block ball bearings
- Completely sealed belt tube to protect V-belt drive
- Extended lube lines
- Heavy duty welded steel construction
- Weather-tight steel curb panel
- Baked polyester powder coat finish with a zinc rich primer
- Rugged galvanized damper section with butterfly damper blades
- Damper rods turn in nylon bearings and require no lubrication



APPLICATIONS

- General ventilation
- Moisture laden air
- Exhaust, heat or smoke fumes
- Mild contaminants in the air stream

ACCESSORIES / OPTIONS

- Pre-fabricated roof curbs
- Explosion proof & special duty motors
- Hot dipped galvanized construction
- 304 or 316 stainless steel construction
- Disconnect switches, mounted or mounted & wired
- Magnetic damper pads for positive closure
- Baked epoxy powder coat finish, two layers
- AMCA spark resistant construction - consult factory

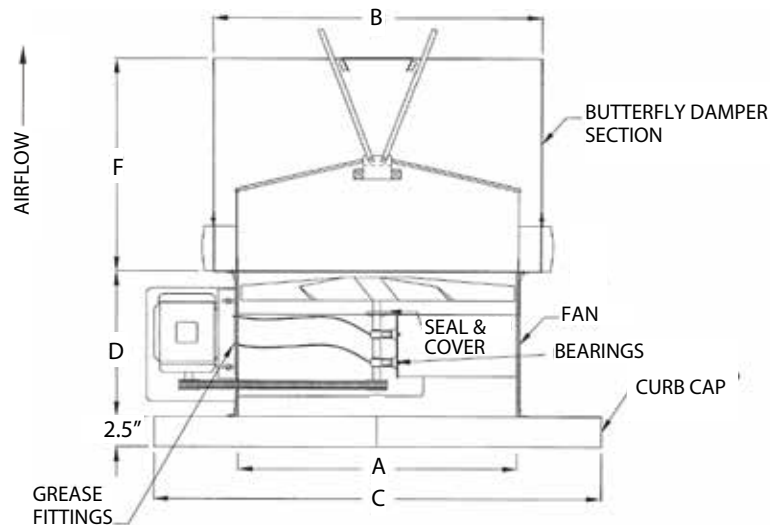

| MODEL | DIMENSIONS IN INCHES* | | | | | WT (lbs) LESS MTR | MAX MTR FRAME |
|--------|-----------------------|----|--------|----|------|----------------------|------------------|
| | A | B | C | D | F | | |
| UBV-18 | 18 | 24 | 33 SQ. | 18 | 20.0 | 240 | 145T |
| UBV-24 | 24 | 30 | 39 SQ. | 18 | 24.0 | 333 | 182T |
| UBV-30 | 30 | 36 | 45 SQ. | 18 | 26.0 | 430 | 184T |
| UBV-36 | 36 | 42 | 51 SQ. | 18 | 30.5 | 455 | 213T |
| UBV-42 | 42 | 48 | 57 SQ. | 22 | 33.0 | 650 | 215T |
| UBV-48 | 48 | 54 | 63 SQ. | 24 | 33.5 | 680 | 215T |
| UBV-54 | 54 | 60 | 69 SQ. | 30 | 39.5 | 810 | 215T |
| UBV-60 | 60 | 66 | 75 SQ. | 30 | 40.0 | 850 | 254T |

*DO NOT USE FOR CONSTRUCTION

CONSULT FACTORY FOR CERTIFIED PRINTS

| MODEL | AIRFLOW PERFORMANCE (CFM) | |
|--------|---------------------------|---------|
| | MINIMUM | MAXIMUM |
| UBV-18 | 2,650 | 5,350 |
| UBV-24 | 4,715 | 10,500 |
| UBV-30 | 7,365 | 16,440 |
| UBV-36 | 10,605 | 22,500 |
| UBV-42 | 14,435 | 33,300 |
| UBV-48 | 18,432 | 41,200 |
| UBV-54 | 25,984 | 45,472 |
| UBV-60 | 29,445 | 61,000 |

MINIMUM CFM VALUE REQUIRED TO OPEN DAMPER BLADES

HRV HOODED ROOF VENTILATORS

FEATURES & BENEFITS

- Supply or exhaust applications
- Direct drive (HRVD) or belt drive (HRVB) arrangements
- Spark resistant, cast aluminum airfoil axial impeller
- Factory set adjustable pitch impeller
- Aerodynamically efficient performance
- Heavy duty welded steel base
- Baked polyester powder coat finish with a zinc rich primer
- Hinged aluminum hood with galvanized birdscreen
- TEFC industrial duty motor
- Direct drive units are easily maintained – no belts or pulleys
- Belt drive units have self-aligning pillow block bearings
- Belt drive units use v-belt drive for low speed operation



APPLICATIONS

- General ventilation
- Make-up air
- Fume and smoke exhaust
- Filtered air supply
- Heat exhaust

ACCESSORIES / OPTIONS

- Filtered intake unit
- Gravity shutter for exhaust only
- Pre-fabricated roof curbs
- Custom curb panel to match existing curb
- Explosion proof motors
- Special duty motors
- 2" thick disposable filters, for filtered intake unit
- Variable pitch sheaves for easy & accurate adjustment
- Disconnect switch - mounted, or mounted & wired
- Motor operated damper for supply or exhaust applications
- Baked epoxy powder coat finish, two layers
- AMCA spark resistant construction - consult factory

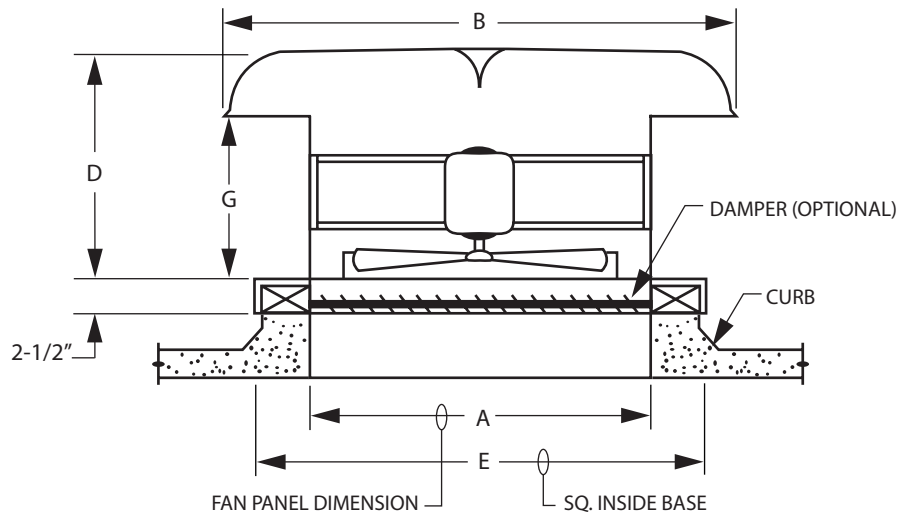

| MODEL | DIMENSIONS IN INCHES* | | | | | WT (lbs) LESS MTR | MAX MTR FRAME | HP |
|--------|-----------------------|----------|------|----|----|----------------------|------------------|---------|
| | A | B | D | E | G | | | |
| HRV-24 | 30 | 54 x 64 | 41.5 | 39 | 28 | 324 | 145T | ¼ - 1 |
| HRV-30 | 36 | 60 x 76 | 41.5 | 45 | 28 | 365 | 145T | ⅓ - 1 ½ |
| HRV-36 | 42 | 72 x 82 | 45.5 | 51 | 30 | 410 | 145T | ½ - 2 |
| HRV-42 | 48 | 80 x 89 | 45.5 | 57 | 30 | 503 | 184T | ½ - 3 |
| HRV-48 | 54 | 87 x 95 | 49.5 | 63 | 32 | 630 | 184T | ¾ - 5 |
| HRV-54 | 60 | 92 x 98 | 50.5 | 69 | 32 | 870 | 215T | 1 - 5 |
| HRV-60 | 66 | 90 x 107 | 54.5 | 75 | 34 | 1140 | 215T | 1 - 10 |

| MODEL | AIRFLOW PERFORMANCE (CFM) | | |
|--------|---------------------------|---------|--------------------------|
| | MINIMUM | MAXIMUM | MAXIMUM CFM W/FILTERS |
| HRV-24 | 800 | 6,700 | 4,875 |
| HRV-30 | 800 | 11,800 | 12,000 |
| HRV-36 | 1,800 | 15,376 | 14,000 |
| HRV-42 | 3,300 | 22,296 | 16,000 |
| HRV-48 | 4,283 | 30,900 | 18,000 |
| HRV-54 | 8,000 | 35,238 | 17,500 |
| HRV-60 | 9,600 | 47,000 | 32,000 |

*DO NOT USE FOR CONSTRUCTION

CONSULT FACTORY FOR CERTIFIED PRINTS

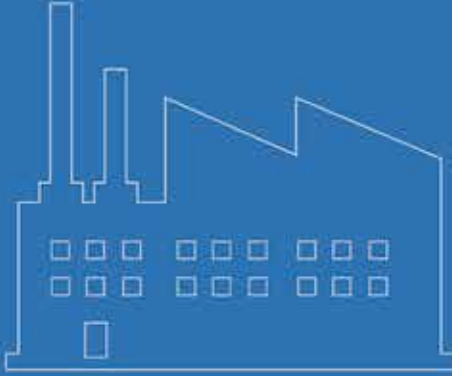

***Industrial Fans
& Blowers***



***OEM Solutions
& Custom Fans***



***Commercial Fans
& Dampers***



***Residential Fans &
Air Purifiers***



Industrial Fans & Blowers

Continental Fan Manufacturing Inc.
Buffalo, NY ~ Dayton, OH

Continental Fan Canada Inc.
Mississauga, ON

continentalfan.com
1-800-779-4021

Distributed by:

