

TNC CENTRIFUGAL COOLING FANS

FEATURES & BENEFITS

- Highly efficient airfoil 'TEK' impellers
- Exceptionally quiet, rapid heat dissipation
- High pressure capability
- Custom mounting arrangements available
- Standard NEMA motors
- Nine sizes available; capacities to 5,000 cfm

APPLICATIONS

- Clean room modules
- Heat exchangers
- Computer rooms
- Air filtration
- Dust collection
- Fume hoods
- Electronic cabinet cooling
- Refrigeration equipment
- Motor control cabinets

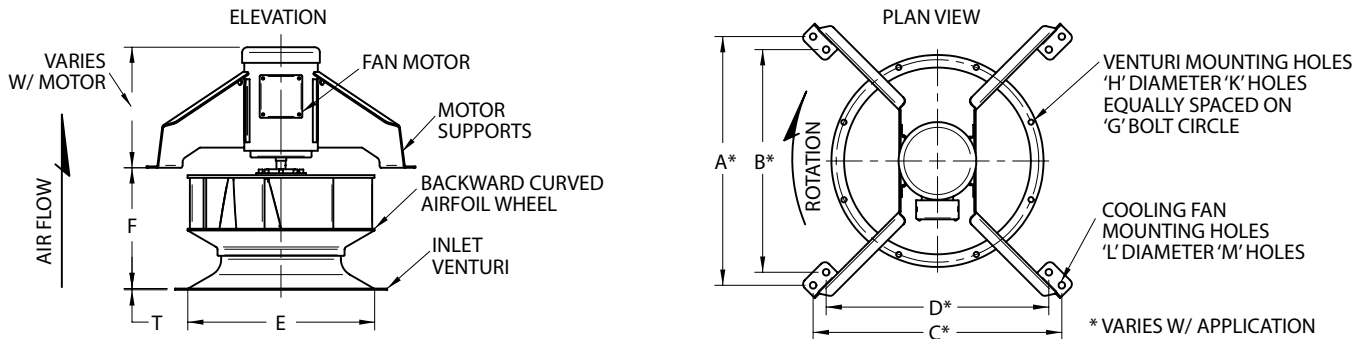
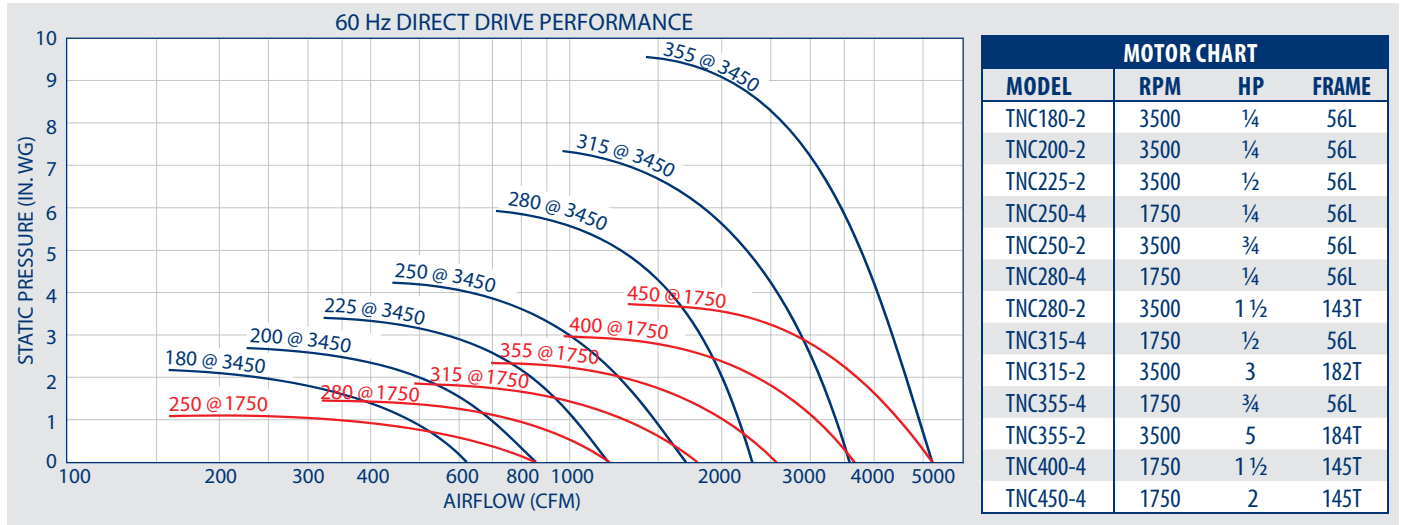

DIMENSIONS IN INCHES*												
MODEL	A	B	C	D	E	F	G	H	K	L	M	T
TNC180-2	14.8	-	15.5	-	7.2	6.5	8.0	0.4	6	0.4	4	0.09
TNC200-2	14.8	-	15.5	-	8.0	7.0	9.1	0.4	6	0.4	4	0.09
TNC225-2	14.8	-	15.5	-	8.9	7.8	10.1	0.4	6	0.4	4	0.09
TNC250-4	14.8	-	15.5	-	10.0	8.5	11.1	0.4	6	0.4	4	0.12
TNC250-2	14.8	-	15.5	-	10.0	8.5	11.1	0.4	6	0.4	4	0.12
TNC280-4	14.8	-	15.5	-	11.2	9.0	12.6	0.4	6	0.4	4	0.12
TNC280-2	14.8	-	15.5	-	11.2	9.0	12.6	0.4	6	0.4	4	0.12
TNC315-4	14.8	-	15.5	-	12.6	9.8	14.0	0.4	6	0.4	4	0.12
TNC315-2	23.7	21.2	23.7	21.2	12.6	10.5	14.0	0.5	6	0.6	8	0.12
TNC355-4	14.8	-	15.5	-	14.2	11.0	15.6	0.5	8	0.4	4	0.12
TNC355-2	23.7	21.2	23.7	21.2	14.2	11.5	15.6	0.5	8	0.6	8	0.12
TNC400-4	23.7	21.2	23.7	21.2	16.0	10.6	17.3	0.5	8	0.6	8	0.17
TNC450-4	23.7	21.2	23.7	21.2	17.3	11.5	19.3	0.5	8	0.6	8	0.17

*DO NOT USE FOR CONSTRUCTION

CONSULT FACTORY FOR CERTIFIED PRINTS

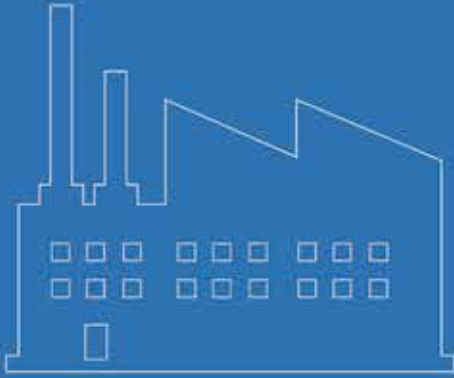

***Industrial Fans
& Blowers***



***OEM Solutions
& Custom Fans***



***Commercial Fans
& Dampers***



***Residential Fans &
Air Purifiers***



OEM Solutions & Custom Fans

Continental Fan Manufacturing Inc.
Buffalo, NY ~ Dayton, OH

Continental Fan Canada Inc.
Mississauga, ON

continentalfan.com
1-800-779-4021

