

ENERGY RECOVERY VENTILATORS

ECO-FLO ENERGY RECOVERY VENTILATOR



The ECO-FLO Energy Recovery Ventilator (ERV) is the all-in-one ventilation solution for new construction and renovation projects involving homes, apartments, or commercial buildings. The ERV core extracts thermal energy and moisture from the exhausted air, and uses it to pre-treat the incoming supply air.

Features & Benefits

- Extracts stale indoor air
- Recovers thermal energy from extracted air
- Supplies fresh, pre-treated air
- Maintains a comfortable humidity setting
- Moisture damage prevention
- Lowers heating and cooling costs throughout the year
- Low energy demand (7 W)
- Quiet operation (as low as 0.2 SONES)
- Multifunctional wireless remote control
- Plug-&-Play installation
- Air purification (MERV 5)
- Rated for continuous operation
- Maximum 500 square feet ventilation applications w/one unit
- Ventilate entire home or commercial building w/ multiple units
- Operate units independently or wired for primary-secondary operation

Controls & Accessories ~ pages 24-25

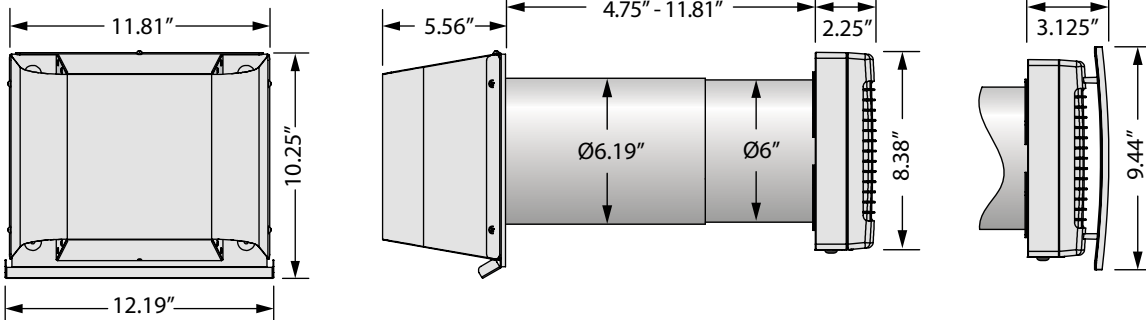

		PERFORMANCE									
MODEL	MANUFACTURE CODE	THERMAL RECOVERY	SPEED	RPM	SONES @ 3M	WATTS	AMPS	CFM	TRANSPORTED AIR TEMP. (F)	POWER SUPPLY	
ECO-FLO	RA1-50-2	88%	LOW	610	0.2	4.50	0.024	12	FROM -4 UP TO 104	120V 60Hz 1 Phase	
			MED	800	0.4	5.00	0.026	21			
			HIGH	1450	0.5	7.00	0.039	30			

IP24 PROTECTION

ECO-FLO Construction

1. Front grille with automatic shutter
 - Easy access for filter cleaning or replacement
 - Made of high quality snow-white ABS plastic
2. Reversible axial fan
 - Reversible DC ball bearing motor
 - Integrated overheating protection
3. Telescopic duct
 - 6" diameter
 - Suitable for walls of varying thickness
4. Air filters (MERV 5)
 - Two filters provide air free of dust and pollen
 - Filters are washable for easy maintenance
5. ERV core
 - Recovery efficiency of 88% @32 F
 - Anti-bacterial treatment
6. Exterior-mounted hood
 - Stainless steel
 - Corrosion proof

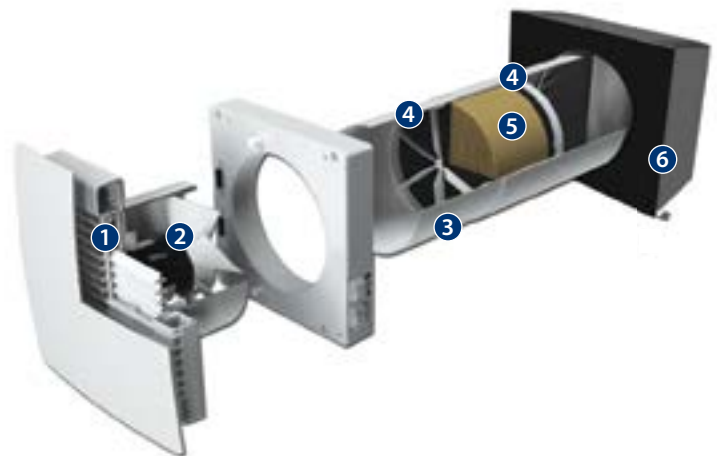

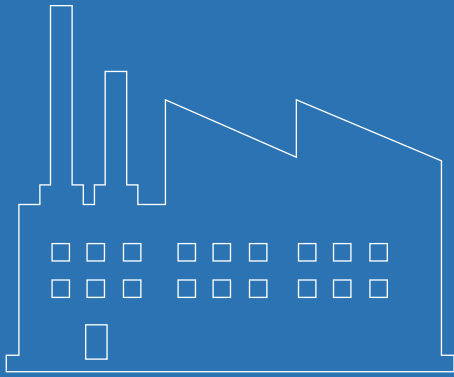

***Industrial Fans
& Blowers***

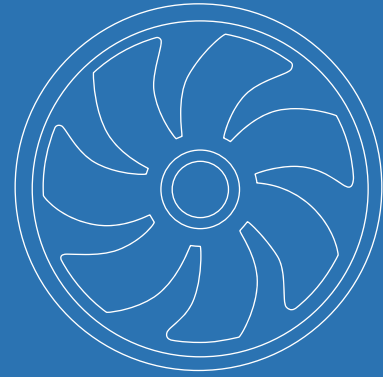

***OEM Solutions
& Custom Fans***



***Commercial Fans
& Dampers***



***Residential Fans &
Air Purifiers***



Wholesale Ventilation Products

Continental Fan Manufacturing Inc.
Buffalo, NY ~ Dayton, OH

Continental Fan Canada Inc.
Mississauga, ON

www.continentalfan.com
1-800-779-4021

Distributed by:

