



Industrial Fans & Blowers



... better AIRFLOW by DESIGN!

INDUSTRIAL FANS & BLOWERS

HISTORY, DEDICATION, AND EXPERIENCE



Continental Fan was established in 1986 to manufacture and distribute quality ventilation equipment. Our objectives then were simple ... to provide superior products, dependable service, competitive pricing, and a knowledgeable staff to satisfy our customers' needs. They remain unchanged today.

Industry leading **CFM** air moving equipment has earned an excellent reputation through years of exceptional performance and reliable operation. We offer the largest quick ship program available and fast deliveries for those products not in stock.

Our experienced and friendly staff delivers customer service that is second to none. We are happy to entertain inquiries for custom fans and provide our customers with 3D models for their air moving solutions. In short, we provide ...

better AIRFLOW by DESIGN™.



CFM SELECT

For latest pricing and fan selection, create an account at cfmselect.com.



TERMS & CONDITIONS OF SALE

For terms and conditions of sale, visit continentalfan.com.



TABLE OF CONTENTS

PANEL & FLANGE FANS

- [AFK-ECM Direct Drive Flange Fans](#) 4
- [AFK Direct Drive Flange Fans](#) 5
- [APK Direct Drive Panel Fans](#) 6
- [ADP Direct Drive Panel Fans](#) 7
- [ABP Belt Drive Panel Fans](#) 8
- [AFF Filtered Fans](#) 9
- [Packaged Panel Fan Option](#) 10

IN-LINE FANS

- [AVD Vaneaxial Fans](#) 11
- [AIDC Contra-Rotating Fans](#) 12
- [AID Direct Drive Axial In-Line Fans](#) 13
- [ADD Direct Drive Tubeaxial Fans](#) 14
- [AIB Belt Drive Tubeaxial Fans](#) 15
- [TID Direct Drive Centrifugal In-Line Fans](#) 16
- [AXC In-Line Duct Fans](#) 17

ROOF VENTILATORS

- [UDVL Direct Drive Upblast Roof Ventilators](#) 18
- [UBVL Belt Drive Upblast Roof Ventilators](#) 19
- [UBV Belt Drive Upblast Roof Ventilators](#) 20
- [HRV Hooded Roof Ventilators](#) 21

CENTRIFUGAL FANS & BLOWERS

- [TCD BC Airfoil Blowers](#) 22
- [TFD Flange Mount Blowers](#) 23
- [CPB Cast Aluminum Pressure Blowers](#) 24
- [CAB Cast Aluminum Blowers](#) 26

PLUG & PLENUM FANS

- [TEK Plug Fans](#) 27
- [TEK-ECM Plenum Fans](#) 28
- [TEK Plenum Fans](#) 29

OEM & REPLACEMENT IMPELLERS

- [TEK Centrifugal BC Airfoil Impellers](#) 30
- [Axial Airfoil Impellers](#) 31

HVLS FANS

- [CMX HVLS Fans](#) 32

DESTRATIFICATION FANS

- [DSF Destratification Fans](#) 33

DAMPERS

- [IRIS Dampers](#) 34

CUSTOM FANS

- [Customized Applications](#) 35

For Product Specification Guides, visit continentalfan.com.

PANEL & FLANGE FANS

AFK-ECM DIRECT DRIVE FLANGE FANS

FEATURES & BENEFITS

- Ideal for maximum savings on variable speed applications
- IE5 efficiency, electronically commutated (EC) motors
- Plug-and-play integrated motor and drive
- Bluetooth communication and programming software available
- 1 to 10 HP motors available for 50/60Hz supply
- Single phase 110-115V or 200-240V; 3-phase 200-240V or 380-480V
- Supply, exhaust or fully reversible configurations
- Cast aluminum airfoil impellers as standard, optional GRP available
- Heavy gauge steel construction with baked polyester finish
- Customizable for OEM applications or new construction
- Sizes range from 12" to 42"
- Capacities up to 40,000 cfm



APPLICATIONS

- General ventilation
- Industrial drying
- Renewable energy
- OEM cabinet cooling
- Variable speed AHUs
- Circulation / recirculation units

ACCESSORIES / OPTIONS

- Special coatings
- Special materials
- Mounting panel
- Motor side guard
- Impeller side guard
- Reverse flow construction
- Housing yoke with mounting bracket
- Axial- or top-mount drive up to 7.5 HP motors
- Top-mount drive for 10 HP motors

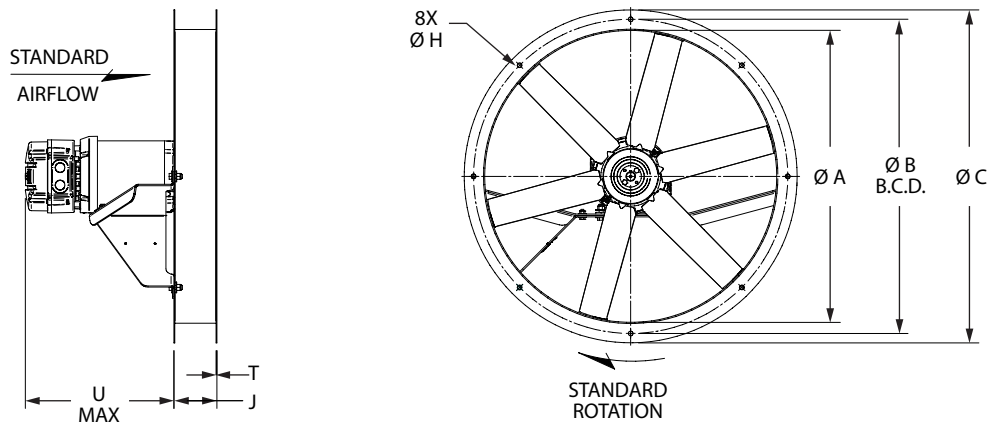

DIMENSIONS IN INCHES*

MODEL	A	B	C	H	J	T	U MAX	MAX MTR FRAME
AFK-12-ECM	12.2	13.8	15.0	0.44	3.0	0.06	14.5	143/5T
AFK-14-ECM	14.2	16.3	17.5	0.44	3.0	0.06	14.5	143/5T
AFK-16-ECM	16.2	18.0	19.5	0.44	4.0	0.08	14.5	143/5T
AFK-18-ECM	18.2	20.8	22.0	0.44	4.0	0.08	14.5	143/5T
AFK-21-ECM	21.2	23.3	24.5	0.44	4.0	0.08	14.5	143/5T
AFK-24-ECM	24.2	26.3	27.5	0.44	4.0	0.08	19.5	182/4T
AFK-27-ECM	27.2	29.3	31.0	0.44	4.0	0.08	19.5	182/4T
AFK-30-ECM	30.2	32.6	34.5	0.56	4.0	0.11	20.5	213/5T
AFK-36-ECM	36.2	38.4	40.5	0.56	5.0	0.11	20.5	213/5T
AFK-42-ECM	42.2	44.6	46.5	0.56	5.0	0.11	15.9 (top drive)	213/5T

*DO NOT USE FOR CONSTRUCTION

CONSULT FACTORY FOR CERTIFIED PRINTS

AFK DIRECT DRIVE FLANGE FANS

FEATURES & BENEFITS

- Spark resistant, cast aluminum airfoil axial impeller
- Unit can be built for supply or exhaust configurations
- Superior performance and sound characteristics
- Heavy gauge steel
- Baked polyester powder coat finish
- TEFC industrial duty motor
- GRP (polypropylene) impeller available
- Ideal for OEM applications or new construction
- Fully reversible design option available
- Sizes range from 12" to 42"
- Capacities to 34,000 cfm from stock components
- Custom designs available



APPLICATIONS

- General ventilation
- Industrial drying
- Renewable energy
- OEM condensing units
- Marine / shipboard applications
- Circulation / recirculation units

ACCESSORIES / OPTIONS

- Special coatings
- Special materials
- Mounting panel
- Motor side guard
- Impeller side guard
- Reverse flow construction
- Housing yoke with mounting bracket
- AMCA spark resistant construction - consult factory
- Explosion proof & special duty motors

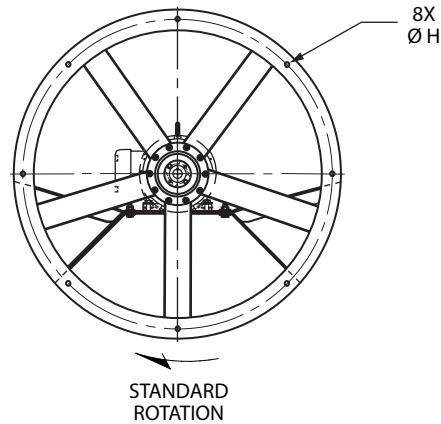
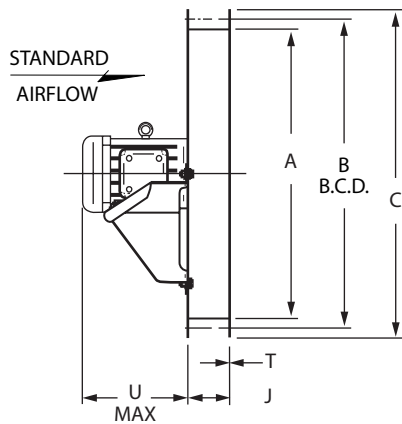

DIMENSIONS IN INCHES*

MODEL	A	B	C	H	J	T	U MAX	MAX MTR FRAME
AFK-12	12.2	13.8	15.0	0.44	3.0	0.06	11.5	143/5T
AFK-14	14.2	16.3	17.5	0.44	3.0	0.06	11.5	143/5T
AFK-16	16.2	18.0	19.5	0.44	4.0	0.08	11.5	143/5T
AFK-18	18.2	20.8	22.0	0.44	4.0	0.08	11.5	143/5T
AFK-21	21.2	23.3	24.5	0.44	4.0	0.08	11.5	143/5T
AFK-24	24.2	26.3	27.5	0.44	4.0	0.08	11.5	143/5T
AFK-27	27.2	29.3	31.0	0.44	4.0	0.08	13.3	182/4T
AFK-30	30.2	32.6	34.5	0.56	4.0	0.11	16.5	213/5T
AFK-36	36.2	38.4	40.5	0.56	5.0	0.11	16.5	213/5T
AFK-42	42.2	44.6	46.5	0.56	5.0	0.11	21.5	254/6T

*DO NOT USE FOR CONSTRUCTION

CONSULT FACTORY FOR CERTIFIED PRINTS

PANEL & FLANGE FANS

APK DIRECT DRIVE PANEL FANS

FEATURES & BENEFITS

- Spark resistant, cast aluminum airfoil axial impeller
- Superior performance and sound characteristics
- Heavy gauge steel
- Baked polyester powder coat finish
- TEFC industrial duty motor
- GRP (polypropylene) impeller available
- Aluminum construction available
- Sizes range from 12" to 36"
- Capacities to 23,000 cfm from stock components
- Custom designs available



APPLICATIONS

- OEM
- Replacement parts
- New construction

ACCESSORIES / OPTIONS

- Weather hood
- Motor & impeller side guards
- Motorized & gravity dampers
- Mounting boot
- Filter cabinet
- AMCA spark resistant construction - consult factory

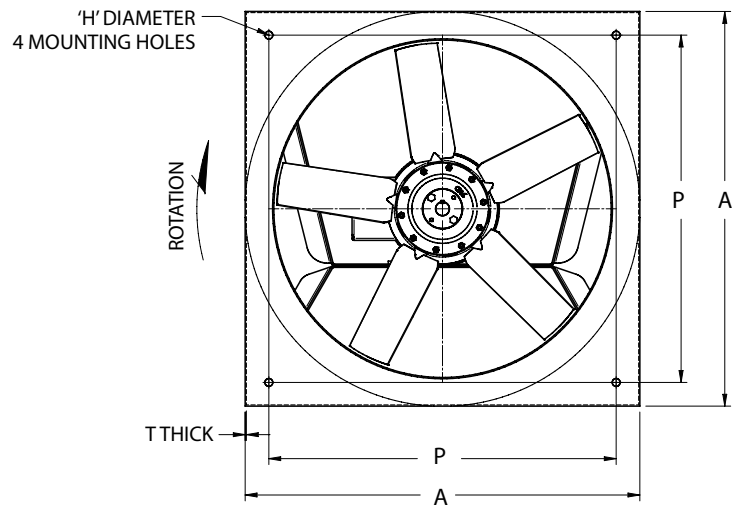
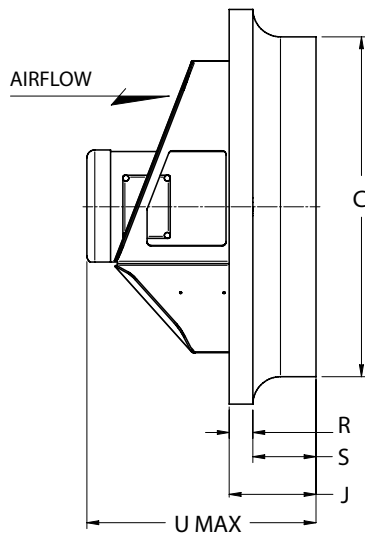

DIMENSIONS IN INCHES*

MODEL	A	C	H	J	P	R	S	T	U MAX	MAX MTR FRAME
APK-12	16	12.4	0.5	4.0	13.0	1.5	2.5	0.06	14.8	143/5T
APK-14	18	14.4	0.5	3.5	15.0	1.0	2.5	0.06	14.8	143/5T
APK-16	20	16.4	0.5	4.3	17.0	1.3	3.0	0.06	14.8	143/5T
APK-18	22	18.4	0.5	4.8	19.0	1.3	3.5	0.08	14.8	143/5T
APK-21	25	21.4	0.5	5.5	22.0	1.5	4.0	0.08	14.8	143/5T
APK-24	28	24.4	0.5	5.5	25.0	1.5	4.0	0.08	16.8	182/4T
APK-27	32	27.4	0.5	5.5	29.0	1.5	4.0	0.08	16.8	182/4T
APK-30	36	30.4	0.4	5.5	33.3	2.0	3.5	0.08	20.6	213/5T
APK-36	42	36.4	0.4	6.0	39.3	2.0	4.0	0.08	26.1	213/5T

*DO NOT USE FOR CONSTRUCTION

CONSULT FACTORY FOR CERTIFIED PRINTS

ADP DIRECT DRIVE PANEL FANS

FEATURES & BENEFITS

- Spark resistant, cast aluminum airfoil axial impeller
- Aerodynamically efficient performance
- Factory set adjustable pitch impeller
- Heavy duty welded steel frame and panel construction
- Baked polyester powder coat finish
- Simple maintenance - no belts or pulleys
- TEFC industrial duty motor
- Broad range of static pressures available
- Sizes range from 12" to 60"
- Capacities to 57,200 cfm



APPLICATIONS

- Power plant ventilation
- Warehouse ventilation
- Foundry ventilation
- General ventilation
- Factory ventilation
- Parking garage ventilation

ACCESSORIES / OPTIONS

- Motor operated shutters
- Gravity shutters
- Bird screen for shutters
- Motor & impeller side guards
- 304 stainless steel construction
- 316 stainless steel construction
- Reverse flow construction
- Special duty motors
- Mounting boot - interior or exterior mount
- Weather hood complete with bird screen
- Baked epoxy powder coat finish, two layers
- AMCA spark resistant construction - consult factory

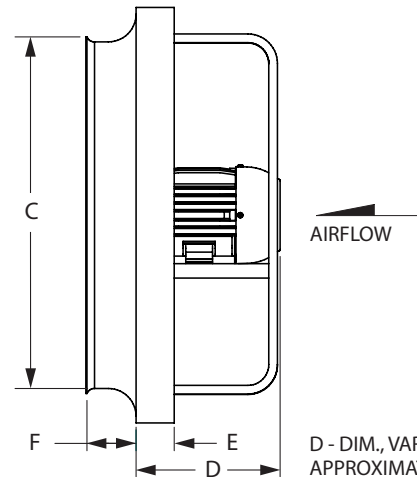
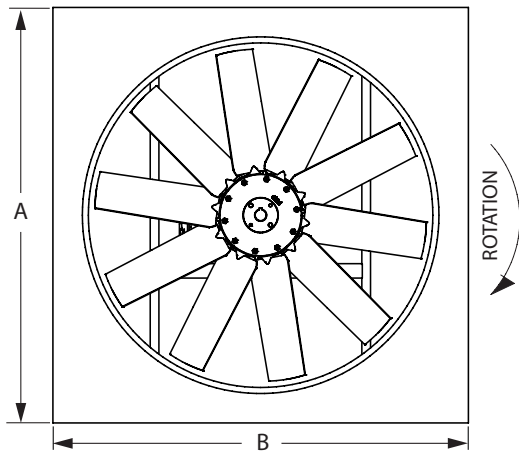

D - DIM., VARIES WITH MOTOR SIZE
APPROXIMATE DIM. SHOWN IN TABLE

DIMENSIONS IN INCHES*

MODEL	A	B	C	D	E	F	WT (lbs) LESS MTR	MAX MTR FRAME
ADP-12	16	16	13.0	11	1.0	1.3	30	56
ADP-16	20	20	17.5	11	1.0	2.3	45	56
ADP-18	24	24	19.5	13	1.0	2.5	50	56
ADP-20	24	24	21.5	13	1.0	2.8	65	145T
ADP-24	30	30	25.5	15	2.8	3.5	105	184T
ADP-30	36	36	31.5	15	2.8	3.5	125	184T
ADP-36	42	42	37.5	15	2.8	4.0	160	184T
ADP-42	48	48	44.0	18	2.8	4.3	180	215T
ADP-48	54	54	50.5	20	2.8	4.5	225	254T
ADP-54	60	60	56.5	22	2.8	4.8	360	256T
ADP-60	66	66	62.0	22	2.8	5.0	495	284T

*DO NOT USE FOR CONSTRUCTION

CONSULT FACTORY FOR CERTIFIED PRINTS

AIRFLOW PERFORMANCE (CFM)

MODEL	MINIMUM	MAXIMUM
ADP-12	500	1,200
ADP-16	500	2,800
ADP-18	1,400	4,150
ADP-20	1,650	6,900
ADP-24	1,800	9,800
ADP-30	2,300	16,000
ADP-36	2,800	23,000
ADP-42	5,800	28,970
ADP-48	7,100	33,000
ADP-54	8,500	43,000
ADP-60	10,800	57,200

PANEL & FLANGE FANS

ABP BELT DRIVE PANEL FANS

FEATURES & BENEFITS

- Spark resistant, cast aluminum airfoil axial impeller
- Aerodynamically efficient performance
- Factory set adjustable pitch impeller
- Heavy duty welded steel frame and panel construction
- Baked polyester powder coat finish
- TEFC industrial duty motor
- Self-aligning pillow block ball bearings
- V-belt drives for low speed operation
- Sizes range from 24" to 60"
- Capacities to 44,600 cfm



APPLICATIONS

- Power plant ventilation
- Warehouse ventilation
- Foundry ventilation
- General ventilation
- Factory ventilation
- Parking garage ventilation

ACCESSORIES / OPTIONS

- Motor operated shutters
- Gravity shutters
- Bird screen for shutters
- Motor & impeller side guards
- Variable pitch sheaves
- Reverse flow construction
- Explosion proof motors
- Special duty motors
- Mounting boot - interior or exterior mount
- Weather hood complete with bird screen
- Baked epoxy powder coat finish, two layers
- AMCA spark resistant construction - consult factory

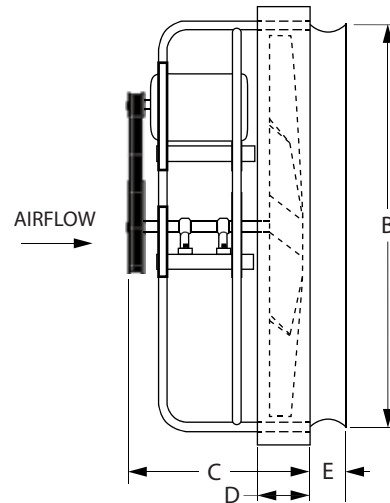
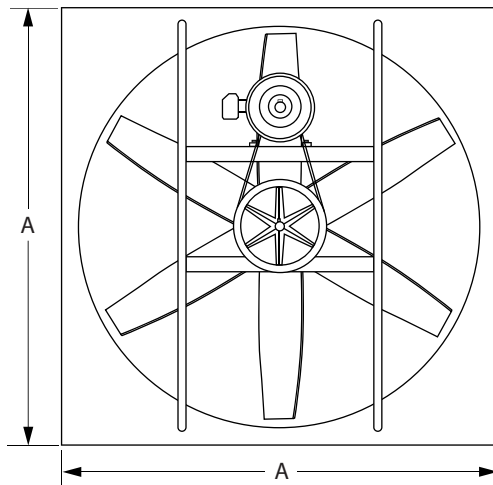

C - DIM., VARIES WITH MOTOR SIZE
APPROXIMATE DIM. SHOWN IN TABLE

MODEL	DIMENSIONS IN INCHES*					WT (lbs) LESS MTR	MAX MTR FRAME
	A	B	C	D	E		
ABP-24	30.0	25.5	20.0	2.8	3.5	100	145T
ABP-30	36.0	31.5	20.0	2.8	3.5	135	145T
ABP-36	42.0	37.5	22.0	2.8	4.0	170	145T
ABP-42	48.0	44.0	24.0	2.8	4.5	185	184T
ABP-48	54.0	50.5	25.0	2.8	4.5	195	184T
ABP-54	60.0	56.5	26.0	2.8	4.8	270	184T
ABP-60	66.0	62.0	28.0	2.8	5.0	330	184T

*DO NOT USE FOR CONSTRUCTION

CONSULT FACTORY FOR CERTIFIED PRINTS

MODEL	AIRFLOW PERFORMANCE (CFM)	
	MINIMUM	MAXIMUM
ABP-24	800	4,900
ABP-30	900	10,600
ABP-36	1,000	16,554
ABP-42	1,642	23,645
ABP-48	5,000	33,160
ABP-54	9,000	37,450
ABP-60	12,850	44,600

AFF FILTERED FANS

FEATURES & BENEFITS

- Spark resistant, cast aluminum airfoil axial impeller
- Supply or exhaust configurations
- OSHA style impeller side guard
- Baked polyester powder coat finish
- Removable filter box section
- TEFC industrial duty motor
- Optional explosion proof motor
- Disposable 2" filters are high capacity, pleated type that meet MERV 8 rating
- Aluminum backdraft damper

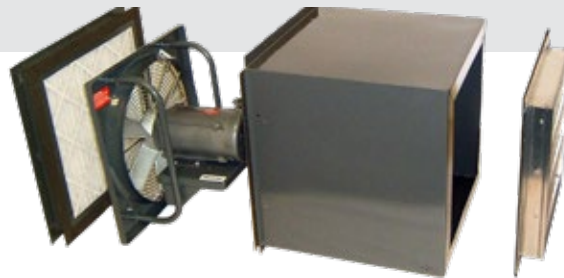

APPLICATIONS

- Unducted paint booths
- Electrical cabinets
- OEM machinery & equipment
- Storage facilities
- Power plant ventilation
- General ventilation

ACCESSORIES / OPTIONS

- Weatherhood
- Coatings for harsh environments
- AMCA spark resistant construction - consult factory

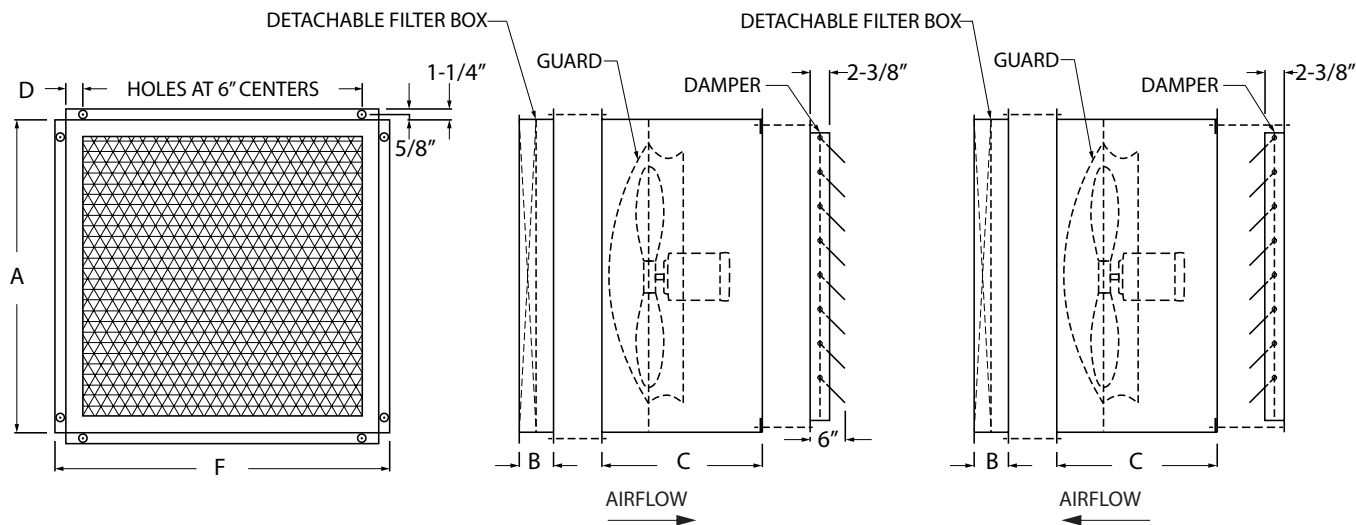

DIMENSIONS IN INCHES*						
MODEL	A	B	C	D	F	FILTER SIZE
AFF-12	16.25	4	20	2	18.75	16x16x2 (1)
AFF-16	20.25	4	20	3	22.75	20x20x2 (1)
AFF-18	24.25	4	20	3	26.75	24x24x2 (1)
AFF-20	24.25	4	22	3	26.75	24x24x2 (1)
AFF-24	30.25	4	25	3	32.75	20x20x2 (1)
						20x10x2 (2)
						10x10x2 (1)
AFF-30	36.25	4	28	3	38.75	18x18x2 (4)
AFF-36	42.25	33	36	3	44.75	18x24x2 (4)
						24x24x2 (4)
AFF-42	48.25	33	37	3	50.75	24x24x2 (8)
AFF-48	54.25	33	37	3	56.75	18x24x2 (12)

PERFORMANCE						
MODEL	ALUMINUM IMPELLER	HP	MOTOR RPM	# FILTERS	CFM	W/FILTERS
AFF-12	12/150/5/21	¼	1800	1	750	
AFF-16	16/150/5/21	¼	1800	1	1,780	
AFF-18	18/150/5/23	½	1800	1	2,600	
AFF-20	20/150/10/20	1	1800	1	3,600	
AFF-24	24/150/5/18	1	1800	4	5,100	
AFF-30	30/150/10/15	1	1200	4	6,000	
AFF-36	36/150/10/18	2	1200	8	11,000	
AFF-42	42/255/4/14	2	1200	8	14,500	
AFF-48	48/255/4/13	3	1200	12	18,750	

*DO NOT USE FOR CONSTRUCTION CONSULT FACTORY FOR CERTIFIED PRINTS

PANEL & FLANGE FANS

PACKAGED PANEL FAN OPTION

FEATURES & BENEFITS

- Supply or exhaust configurations
- Heavy gauge fan and shutter mounting box, factory mounted
- Baked polyester powder coat finish
- Three types of shutters available:
 - Aluminum gravity shutter for exhaust
 - Motor operated shutter for exhaust
 - Motor operated center pivoted for either supply or reversible operation
- OSHA compliant rear box guard:
 - 12, 16, 18, 20 & 54 inch sizes are fabricated expanded metal
 - 24, 30, 36, 42, & 60 inch sizes are formed wire five piece guards

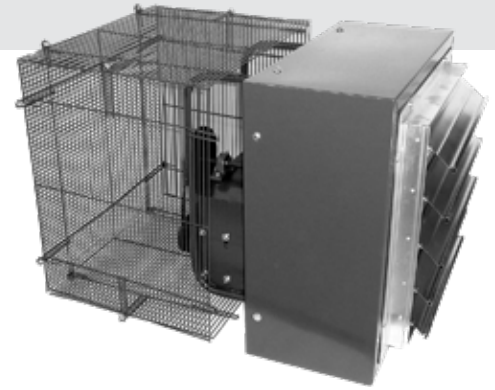

APPLICATIONS

- Designed for use with ADP, ABP & WEB panel fans
- Use as an optional weather hood with bird screen
- Simplify mounting in block, concrete or metal walls

ACCESSORIES / OPTIONS

- Exterior weather hood recommended for intake applications
- AMCA spark resistant construction - consult factory

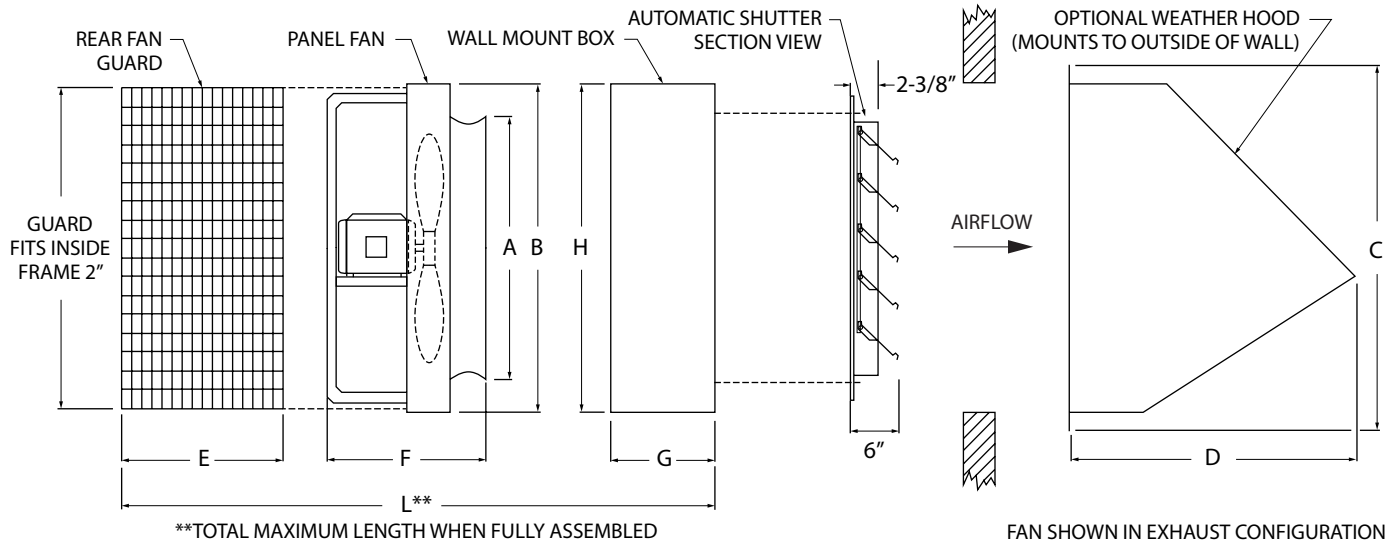

DIMENSIONS IN INCHES*											
FAN SIZE	A	B	C	D	H	G	WALL OPENING	E	F	L**	SHUTTER SIZE
12	13.0	16.0	23.0	22.0	16.25	8.0	16.75	15.0	12.3	22.0	12.0
16	17.5	20.0	27.0	24.0	20.25	9.0	20.75	15.0	13.3	23.0	16.0
18	19.5	24.0	29.0	25.0	24.25	10.0	24.75	15.0	15.5	24.0	18.0
20	21.5	24.0	31.0	26.0	24.25	11.0	24.75	15.0	15.8	25.0	20.0
24	25.5	30.0	35.0	28.0	30.25	14.0	30.75	24.0	18.5	37.0	24.0
30	31.5	36.0	41.0	32.0	36.25	14.0	36.75	24.0	18.5	37.0	30.0
36	37.5	42.0	47.0	36.0	42.25	15.0	42.75	24.0	19.0	38.0	36.0
42	44.5	48.0	53.0	44.0	48.25	16.0	48.75	24.0	22.3	39.0	42.0
48	50.5	54.0	59.0	46.0	54.25	16.0	54.75	24.0	24.5	39.0	48.0
54	56.5	60.0	65.0	50.0	60.25	18.0	60.75	24.0	26.8	41.0	54.0
60	62.0	66.0	71.0	54.0	66.25	18.0	66.75	26.5	27.0	43.5	60.0

*DO NOT USE FOR CONSTRUCTION

CONSULT FACTORY FOR CERTIFIED PRINTS

AVD VANEAXIAL FANS

FEATURES & BENEFITS

- Average 20% pressure gain compared to tubeaxial construction
- Improved fan efficiency due to guide vanes
- No increase in motor horsepower due to downstream guide vanes
- Minimized air swirl reduces long ductwork pressure drops downstream
- High efficiency, cast aluminum airfoil axial impeller
- Heavy gauge steel housings
- Externally mounted & wired junction box
- TEFC severe duty motors as standard
- Sizes range from 12" to 60"
- Capacities to 61,000 cfm

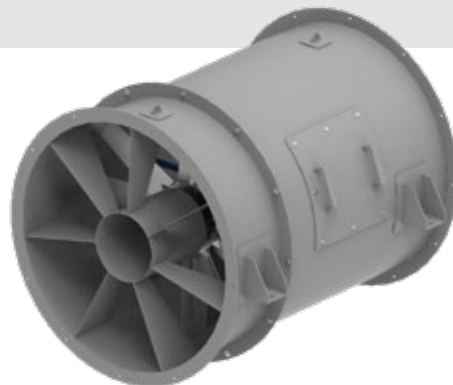

APPLICATIONS

- Process ventilation
- General ventilation
- Booster fans
- High air volume and pressure applications
- Removal of process related fumes, dust and smoke

ACCESSORIES/OPTIONS

- Horizontal mounting brackets
- Vertical mounting brackets
- Companion flanges
- Inspection door
- Motor & impeller side guards
- Continuously welded construction
- 304 or 316 stainless steel housing
- Special motors, IEEE 45, IEEE 841, XP
- Special surface preparation and paint finishes
- AMCA spark resistant construction – consult factory
- Larger diameters and capacities – consult factory

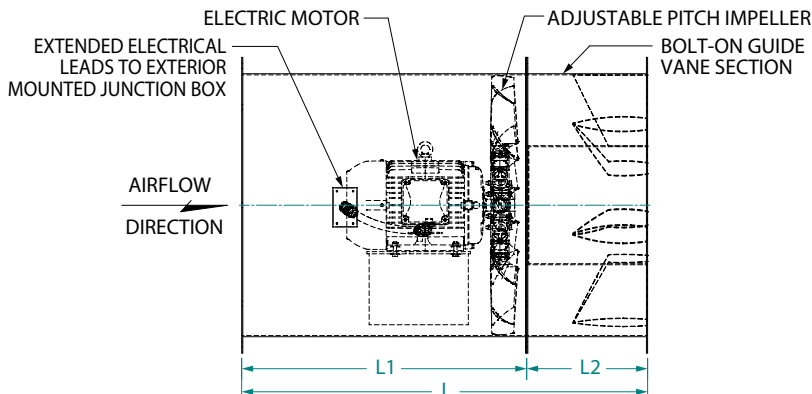
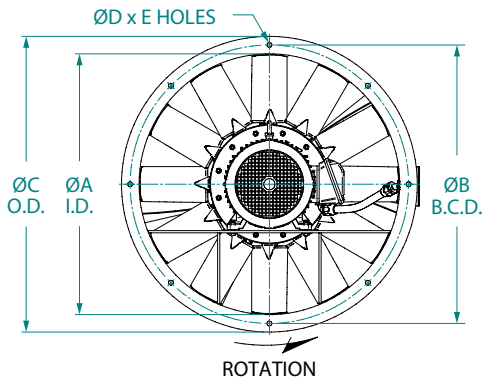

DIMENSIONS IN INCHES*

MODEL	ØA	ØB	ØC	ØD	E	L1	L2	L	MAX MTR FRAME
AVD-12	12.19	13.75	15.00	0.44	8	18.00	8.00	26.00	56
AVD-14	14.19	16.25	17.50	0.44	8	20.00	8.00	28.00	143/5T
AVD-16	16.19	18.00	19.50	0.44	8	21.00	9.00	30.00	143/5T
AVD-18	18.19	20.75	22.00	0.44	8	24.00	9.00	33.00	143/5T
AVD-21	21.19	23.25	24.50	0.44	8	26.00	10.00	36.00	182/4T
AVD-24	24.19	26.25	27.50	0.44	8	29.00	12.00	41.00	182/4T
AVD-27	27.19	29.25	31.00	0.44	8	29.00	14.00	43.00	182/4T
AVD-30	30.19	32.63	34.50	0.56	8	33.00	14.00	47.00	213/5T
AVD-34	34.19	36.63	38.50	0.56	8	33.00	16.00	49.00	213/5T
AVD-36	36.19	38.63	40.50	0.56	8	33.00	17.00	50.00	213/5T
AVD-42	42.19	44.63	46.50	0.56	8	42.00	18.00	60.00	254/6T
AVD-48	48.19	50.63	52.50	0.56	12	42.00	18.00	60.00	254/6T
AVD-54	54.19	56.63	58.50	0.56	12	55.00	22.00	77.00	284/6T
AVD-60	60.19	62.63	64.50	0.56	12	55.00	22.00	77.00	284/6T

*DO NOT USE FOR CONSTRUCTION

CONSULT FACTORY FOR CERTIFIED PRINTS

IN-LINE FANS

AIDC CONTRA-ROTATING FANS

FEATURES & BENEFITS

- Two-stage, contra-rotating fan
- Develops 2.4 times more pressure than a single-stage fan
- Impellers specially built for counter rotation
- Minimized air swirl reduces long ductwork pressure drops downstream
- High efficiency, cast aluminum airfoil axial impellers
- Heavy gauge steel housings
- Externally mounted & wired junction box
- TEFC severe duty motors as standard
- Sizes range from 12" to 60"; capacities to 61,000 cfm

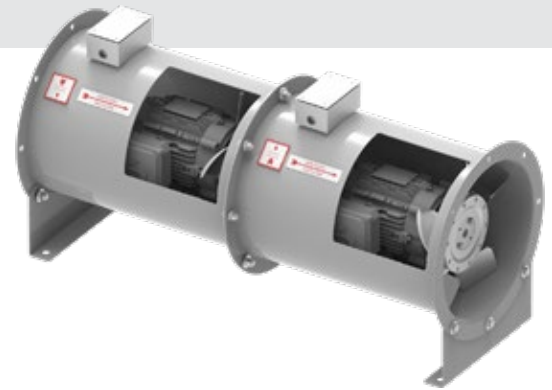

APPLICATIONS

- Process ventilation
- General ventilation
- Booster fans
- High air volume and pressure applications
- Removal of process related fumes, dust and smoke

ACCESSORIES / OPTIONS

- Horizontal mounting brackets
- Vertical mounting brackets
- Companion flanges
- Inspection doors
- Inlet & outlet side guards
- Continuously welded construction
- 304 or 316 stainless steel housing
- Special motors, IEEE 45, IEEE 841, XP
- Special surface preparation and paint finishes
- AMCA spark resistant construction – consult factory
- Larger diameters and capacities – consult factory

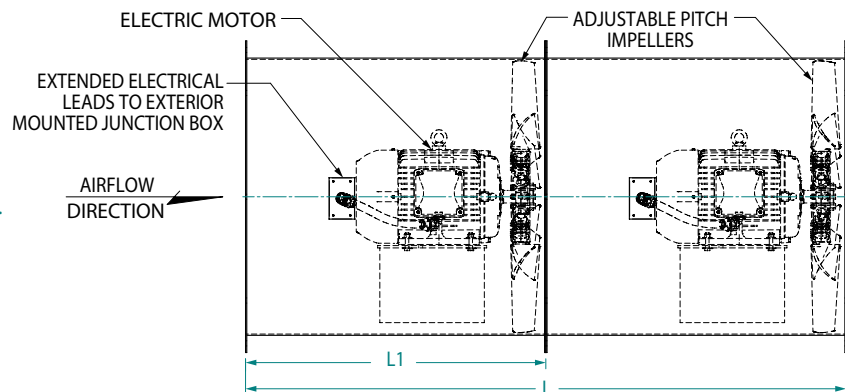
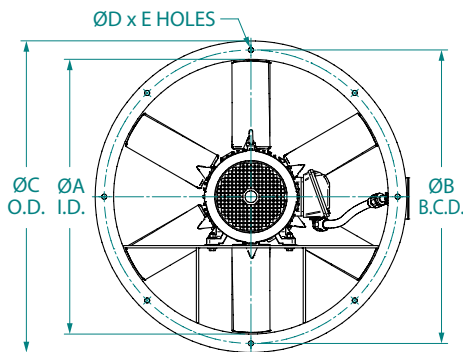

DIMENSIONS IN INCHES*

MODEL	ØA	ØB	ØC	ØD	E	L1	L	MAX MTR FRAME
AIDC-12	12.19	13.75	15.00	0.44	8	18.00	36.00	56
AIDC-14	14.19	16.25	17.50	0.44	8	20.00	40.00	143/5T
AIDC-16	16.19	18.00	19.50	0.44	8	21.00	42.00	143/5T
AIDC-18	18.19	20.75	22.00	0.44	8	24.00	48.00	143/5T
AIDC-21	21.19	23.25	24.50	0.44	8	26.00	52.00	182/4T
AIDC-24	24.19	26.25	27.50	0.44	8	29.00	58.00	182/4T
AIDC-27	27.19	29.25	31.00	0.44	8	29.00	66.00	182/4T
AIDC-30	30.19	32.63	34.50	0.56	8	33.00	66.00	213/5T
AIDC-34	34.19	36.63	38.50	0.56	8	33.00	66.00	213/5T
AIDC-36	36.19	38.63	40.50	0.56	8	33.00	66.00	213/5T
AIDC-42	42.19	44.63	46.50	0.56	8	42.00	84.00	254/6T
AIDC-48	48.19	50.63	52.50	0.56	12	42.00	84.00	254/6T
AIDC-54	54.19	56.63	58.50	0.56	12	55.00	110.00	284/6T
AIDC-60	60.19	62.63	64.50	0.56	12	55.00	110.00	284/6T

*DO NOT USE FOR CONSTRUCTION

CONSULT FACTORY FOR CERTIFIED PRINTS

AID DIRECT DRIVE AXIAL IN-LINE FANS

FEATURES & BENEFITS

- Spark resistant, cast aluminum airfoil axial impeller
- Superior performance and sound characteristics
- Factory set adjustable pitch impeller
- Baked polyester powder coat finish
- NEMA 4 junction box, pre-wired and mounted on fan
- TEFC industrial duty motor
- GRP (polypropylene) impeller available
- Fully reversible airflow option
- Custom mounting arrangements available
- Sizes range from 12" to 27"
- Capacities to 11,400 cfm



APPLICATIONS

- Process ventilation
- Cabinet cooling
- OEM applications

ACCESSORIES / OPTIONS

- Motor side guard
- Impeller side guard
- Mounting feet
- Horizontal mounting brackets
- Explosion proof & special duty motors
- AMCA spark resistant construction - consult factory

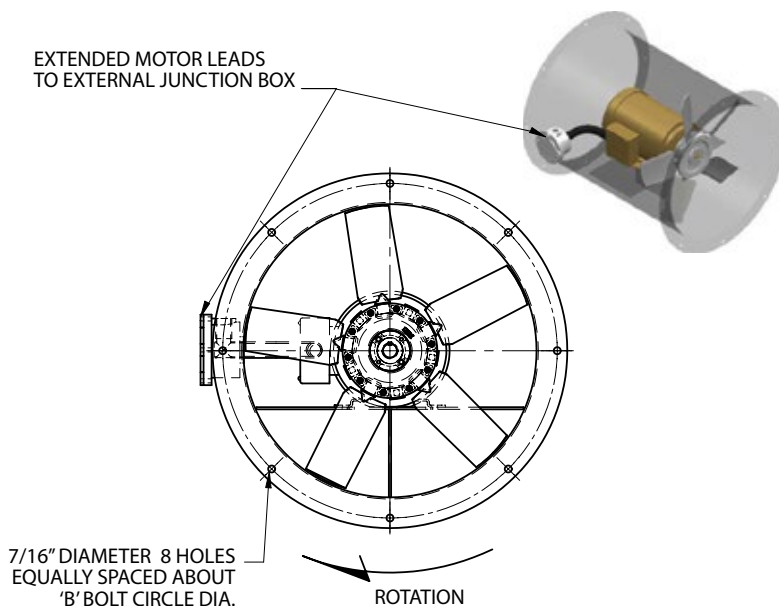
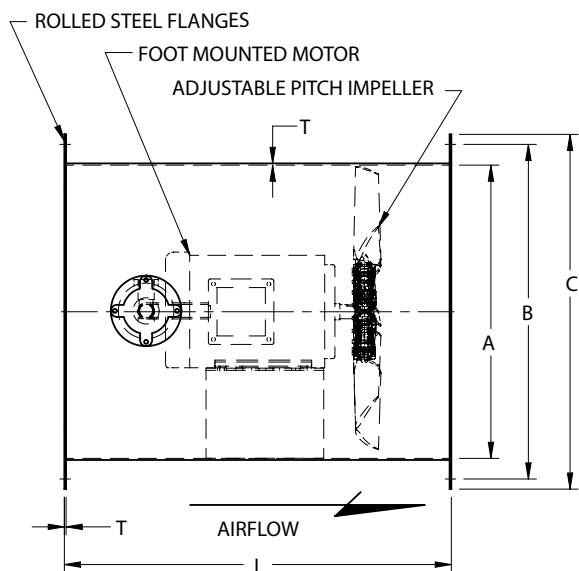

MODEL	DIMENSIONS IN INCHES*					MAX MTR FRAME
	A	B	C	L	T	
AID-12	12.2	13.8	15.0	18.0	0.075	56
AID-14	14.2	16.3	17.5	20.0	0.075	143/5T
AID-16	16.2	18.0	19.5	21.0	0.075	143/5T
AID-18	18.2	20.8	22.0	24.0	0.105	143/5T
AID-21	21.2	23.3	24.5	26.0	0.105	182/4T
AID-24	24.2	26.3	27.5	29.0	0.105	182/4T
AID-27	27.2	29.3	31.0	29.0	0.105	182/4T

MODEL	AIRFLOW PERFORMANCE (CFM)	
	MINIMUM	MAXIMUM
AID-12	500	2,600
AID-14	800	4,200
AID-16	900	5,600
AID-18	1,600	6,800
AID-21	1,600	7,000
AID-24	2,800	9,000
AID-27	3,400	11,400

*DO NOT USE FOR CONSTRUCTION

CONSULT FACTORY FOR CERTIFIED PRINTS

IN-LINE FANS

ADD DIRECT DRIVE TUBEAXIAL FANS

FEATURES & BENEFITS

- Spark resistant, cast aluminum airfoil axial impeller
- Aerodynamically efficient performance
- Factory set adjustable pitch impeller
- Heavy duty welded steel and angle ring construction
- Baked polyester powder coat finish
- Simple maintenance – no belts or pulleys
- Mountable in ductwork in any position
- TEFC industrial duty motor
- Sizes range from 12" to 60"
- Capacities to 61,000 cfm



APPLICATIONS

- Process ventilation
- In-line duct booster
- Removal of process related fumes, dust and smoke
- General ventilation

ACCESSORIES / OPTIONS

- Horizontal mounting brackets
- Vertical mounting brackets
- Mounting legs
- Companion flanges
- Motor side guard
- Impeller side guard
- Reverse flow construction
- Explosion proof & special duty motors
- Externally mounted & wired junction box
- 304 or 316 stainless steel construction
- Baked epoxy powder coat finish, two layers
- AMCA spark resistant construction - consult factor

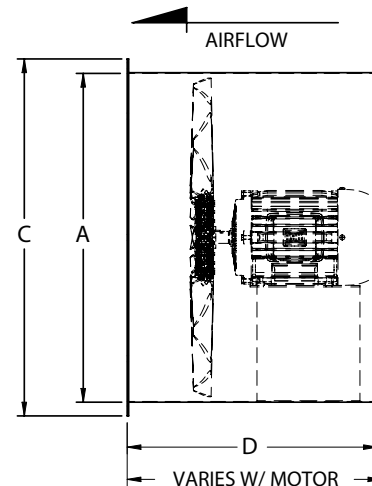
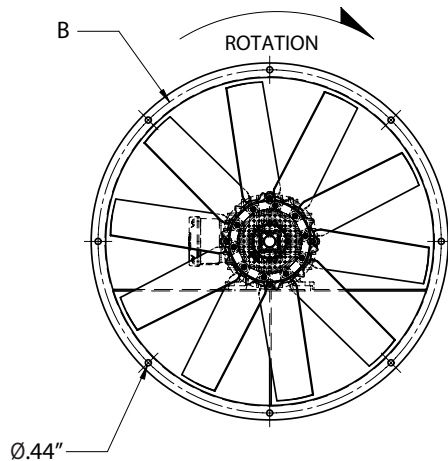

MODEL	DIMENSIONS IN INCHES*				WT (lbs) LESS MTR	MAX MTR FRAME
	A	B	C	D		
ADD-12	12	13.1	14	14	25	56
ADD-18	18	19.1	20	14	50	145T
ADD-24	24	25.8	27	18	100	184T
ADD-27	27	28.8	30	18	110	184T
ADD-30	30	31.8	33	18	115	184T
ADD-34	34	35.8	37	18	145	184T
ADD-36	36	37.9	39	18	210	184T
ADD-42	42	43.6	45	18	245	215T
ADD-48	48	49.6	51	18	275	254T
ADD-54	54	55.6	57	24	645	286T
ADD-60	60	61.6	63	36	750	286T

MODEL	AIRFLOW PERFORMANCE (CFM)	
	MINIMUM	MAXIMUM
ADD-12	600	2,044
ADD-18	1,000	4,600
ADD-24	1,400	10,500
ADD-27	2,000	11,500
ADD-30	2,300	16,000
ADD-34	4,000	21,000
ADD-36	4,500	24,000
ADD-42	5,800	29,000
ADD-48	11,000	41,000
ADD-54	18,000	51,000
ADD-60	24,000	61,000

*DO NOT USE FOR CONSTRUCTION

CONSULT FACTORY FOR CERTIFIED PRINTS

AIB BELT DRIVE TUBEAXIAL FANS

FEATURES & BENEFITS

- Spark resistant, cast aluminum airfoil axial impeller
- Heavy duty welded steel and angle ring construction
- Baked polyester powder coat finish
- Mountable in ductwork in any position
- Factory set adjustable pitch impeller
- TEFC industrial duty motor located outside of air stream
- Self-aligning pillow block ball bearings
- V-belt drives for low speed operation
- Belt tube to protect sheaves and belts from air stream
- Extended lube lines
- Shaft seal & water slinger



APPLICATIONS

- Process ventilation
- General ventilation
- In-line duct booster
- Moisture laden air
- Removal of process related fumes, dust and smoke
- Contaminated air steams

ACCESSORIES / OPTIONS

- Horizontal mounting brackets
- Vertical mounting brackets
- Mounting legs
- Companion flanges
- Variable pitch sheaves
- Impeller side guard
- Motor side guard
- Inspection door
- Reverse flow construction
- Motor cover and/or belt guard
- 304 or 316 stainless steel construction
- Maximum 375 F construction
- Explosion proof & special duty motors
- Baked epoxy powder coat finish, two layers
- AMCA spark resistant construction - consult factory

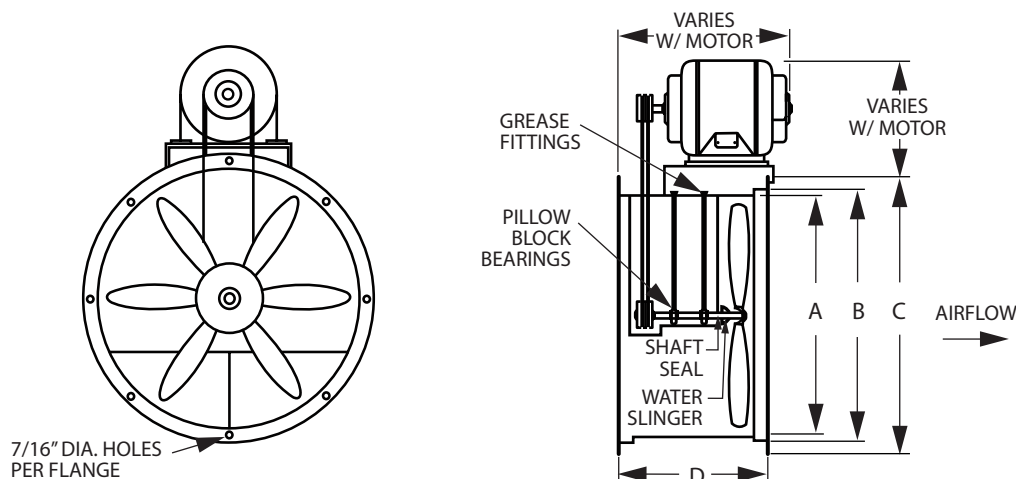

MODEL	DIMENSIONS IN INCHES*				WT (lbs) LESS MTR	MAX MTR FRAME
	A	B	C	D		
AIB-12	12	13.1	14	18	50	143T
AIB-15	15	16.1	17	18	65	143T
AIB-18	18	19.1	20	18	80	145T
AIB-24	24	25.8	27	18	100	184T
AIB-27	27	28.8	30	18	115	184T
AIB-30	30	31.8	33	18	125	184T
AIB-34	34	35.8	37	18	150	184T
AIB-36	36	37.9	39	18	195	215T
AIB-42	42	43.6	45	22	280	215T
AIB-48	48	49.6	51	24	345	215T
AIB-54	54	55.6	57	28	430	215T
AIB-60	60	61.6	63	30	540	215T

MODEL	AIRFLOW PERFORMANCE (CFM)	
	MINIMUM	MAXIMUM
AIB-12	600	2,044
AIB-15	1,000	4,250
AIB-18	1,500	5,350
AIB-24	1,775	11,400
AIB-27	2,000	13,480
AIB-30	3,500	16,440
AIB-34	6,700	20,500
AIB-36	9,500	22,500
AIB-42	9,950	33,300
AIB-48	13,900	41,200
AIB-54	18,000	45,000
AIB-60	20,000	54,000

*DO NOT USE FOR CONSTRUCTION

CONSULT FACTORY FOR CERTIFIED PRINTS

IN-LINE FANS

TID DIRECT DRIVE CENTRIFUGAL IN-LINE FANS



FEATURES & BENEFITS

- Direct drive, non-overloading 'TEK' impeller
- Highly efficient airfoil (BCA) design
- Super quiet, highly efficient performance
- Rugged GRP (polyamide) impeller
- Baked polyester powder coat finish
- NEMA 4 junction box, pre-wired and mounted on fan
- Custom mounting arrangements available
- TEFC industrial duty motor
- Sizes range from 12" to 24"
- Capacities to 4,258 cfm

APPLICATIONS

- Process ventilation
- Cabinet cooling
- General ventilation

ACCESSORIES / OPTIONS

- Mounting feet
- Motor side guard
- Special duty motors
- Inspection door
- Impeller side guard

MODEL	PEAK HP	MTR HP	dBA @5'	AIRFLOW PERFORMANCE (CFM) AT 1740 RPM											
				0"SP	.25"SP	.5" SP	.75" SP	1" SP	1.25" SP	1.5" SP	1.75" SP	2" SP	2.5" SP	3" SP	
TID280	0.16	¼	62	1080	990	880	700	450	-	-	-	-	-	-	
TID315	0.34	½	67	1570	1460	1350	1210	1020	790	490	-	-	-	-	
TID355	0.65	¾	72	2160	2050	1940	1820	1670	1480	1240	940	-	-	-	
TID400	1.23	1½	73	2850	2750	2640	2530	2410	2270	2090	1840	1610	410	-	
TID450	1.82	2	74	4220	4070	3920	3760	3590	3400	3190	2900	2660	1900	590	

MODEL	PEAK HP	MTR HP	dBA @5'	AIRFLOW PERFORMANCE (CFM) AT 3450 RPM										
				0"SP	.5"SP	1" SP	1.5" SP	2" SP	2.5" SP	3" SP	3.5" SP	4" SP	5" SP	6" SP
TID200	0.24	⅓	68	810	740	650	520	380	-	-	-	-	-	-
TID225	0.44	½	73	1020	960	900	810	690	520	140	-	-	-	-
TID250	0.66	¾	75	1530	1450	1360	1260	1120	960	790	510	-	-	-
TID280	1.41	1½	77	2140	2060	1980	1870	1750	1590	1390	1140	850	-	-
TID315	2.58	3	82	3130	3020	2910	2790	2660	2520	2360	2160	1990	1490	500
TID355	4.98	5	86	4258	4146	4037	3928	3814	3692	3560	3412	3248	2857	2342

MODEL	DIMENSIONS IN INCHES*					MAX MTR FRAME
	A	B	C	D	T	
TID200	12.2	13.8	15.0	18	0.075	56
TID225	14.2	16.3	17.5	20	0.075	143/5T
TID250	14.2	16.3	17.5	20	0.075	143/5T
TID280	16.2	18.0	19.5	21	0.075	143/5T
TID315	18.2	20.8	22.0	24	0.105	143/5T
TID355	21.2	23.3	24.5	26	0.105	182/4T
TID400	24.2	26.3	27.5	29	0.105	182/4T
TID450	24.2	26.3	27.5	29	0.105	182/4T

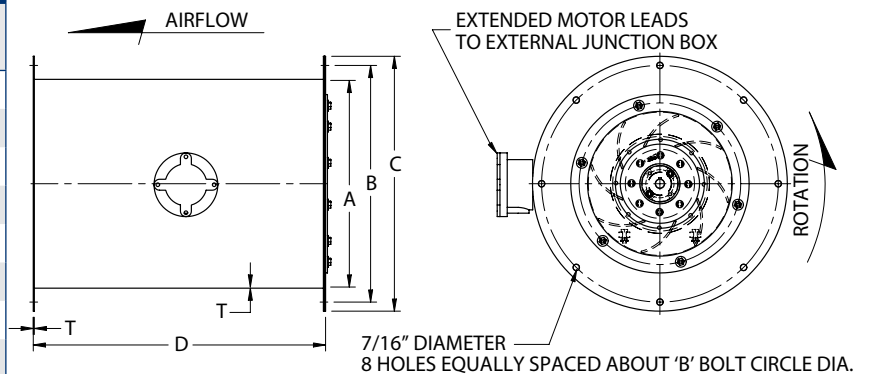

*DO NOT USE FOR CONSTRUCTION
CONSULT FACTORY FOR CERTIFIED PRINTS

AXC IN-LINE DUCT FANS

FEATURES & BENEFITS

- Heavy gauge, drawn steel housing with baked epoxy finish
- 120V operation, other voltages available
- Easy to install - mounting brackets included
- May be mounted in any position
- Fans may be used to supply or exhaust air
- Suitable for air temperatures up to 140 F / 60 C
- Energy efficient - speed controllable (optional solid state speed control)
- Optional pre-wired with 120V power cord (AXC-C)
- Exceptionally quiet and efficient BC centrifugal motorized impeller
- External rotor motor design results in superior motor cooling and durability
- Permanently lubricated ball bearing motor for maintenance-free operation
- Automatic reset thermal overload protection
- Fan and motor are precision balanced for quiet and vibration-free operation
- Easily accessible, external junction box with pre-wired capacitor
- Available to fit duct sizes 4" - 12"; airflow capacities to 970 cfm



APPLICATIONS

- Conference room exhaust
- Computer rooms
- Powered make-up air
- Hair and nail salons
- Equipment and spot cooling
- Humidity and moisture removal

ACCESSORIES / OPTIONS

- Speed controls
- Pressure switches
- Backdraft dampers
- Supply & exhaust grilles
- Mounting clamps
- Roof & wall caps

MODEL	WATTS	RPM	AIRFLOW PERFORMANCE (CFM)								
			0" SP	0.2" SP	0.4" SP	0.6" SP	0.8" SP	1.0" SP	1.2" SP	1.5" SP	2.0" SP
AXC100A-ES	43.3	2580	147	130	107	82	57	34	11	-	-
AXC100B	83.4	2620	150	140	127	112	94	74	53	23	-
AXC125A-ES	44.4	2520	179	150	121	87	49	14	-	-	-
AXC125B	85.4	2750	183	160	141	122	101	77	51	14	-
AXC150A-ES	46.8	2390	235	190	148	97	44	-	-	-	-
AXC150B-ES	89.2	2450	308	260	216	175	139	108	81	47	-
AXC200A-ES	84.5	2500	368	300	234	184	149	114	70	-	-
AXC200B-ES	188	2550	579	520	453	387	329	282	245	206	154
AXC250-ES	198	2470	616	550	488	431	379	330	286	227	143
AXC300A-ES	206	2450	780	700	595	420	330	290	255	210	132
AXC300B-ES	312	2780	970	910	803	680	559	453	367	273	164

FOR PRE-WIRED WITH 120V POWER CORD, ADD -C TO MODEL.

MODEL	DIMENSIONS IN INCHES*				SHIP WT (lbs)
	D	d	A	B	
AXC100A-ES	9.5	3.9	1.0	8.3	7.5
AXC100B	9.5	3.9	1.0	8.3	8.0
AXC125A-ES	9.5	4.8	1.0	8.3	7.5
AXC125B	9.5	4.8	1.0	8.3	7.5
AXC150A-ES	9.5	5.8	1.0	8.3	7.5
AXC150B-ES	13.2	5.8	1.0	9.1	12.5
AXC200A-ES	13.2	7.8	1.0	9.1	12.0
AXC200B-ES	13.2	7.8	1.0	9.1	15.0
AXC250-ES	13.2	9.8	1.0	9.1	15.0
AXC300A-ES	15.9	11.8	1.2	11.8	18.0
AXC300B-ES	15.9	11.8	1.2	11.8	18.0

*DO NOT USE FOR CONSTRUCTION
CONSULT FACTORY FOR CERTIFIED PRINTS

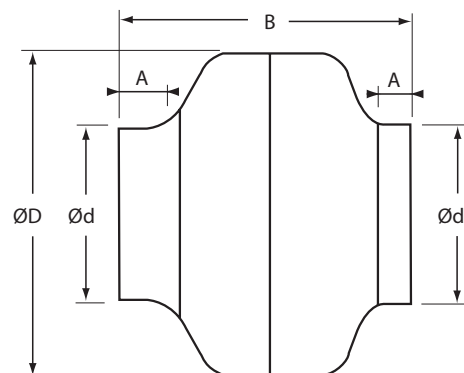

ROOF VENTILATORS

UDVL DIRECT DRIVE UPBLAST ROOF VENTILATORS

FEATURES & BENEFITS

- Low silhouette weatherproof closure for vertical air discharge
- Direct drive, low maintenance
- Spark resistant, cast aluminum airfoil axial impeller
- Factory set adjustable pitch impeller
- Aerodynamically efficient performance
- TEFC industrial duty motor
- Weather-tight steel curb panel
- Heavy duty welded steel construction
- Baked polyester powder coat finish with a zinc rich primer
- Rugged galvanized damper section with butterfly damper blades
- Damper rods turn in nylon bearings and require no lubrication



APPLICATIONS

- General ventilation
- Removal of process related fumes, dust and smoke

ACCESSORIES / OPTIONS

- Pre-fabricated roof curbs
- Explosion proof & special duty motors
- Hot dipped galvanized construction
- 304 or 316 stainless steel construction
- Disconnect switches, mounted or mounted & wired
- Magnetic damper pads for positive closure
- Baked epoxy powder coat finish, two layers
- AMCA spark resistant construction - consult factory

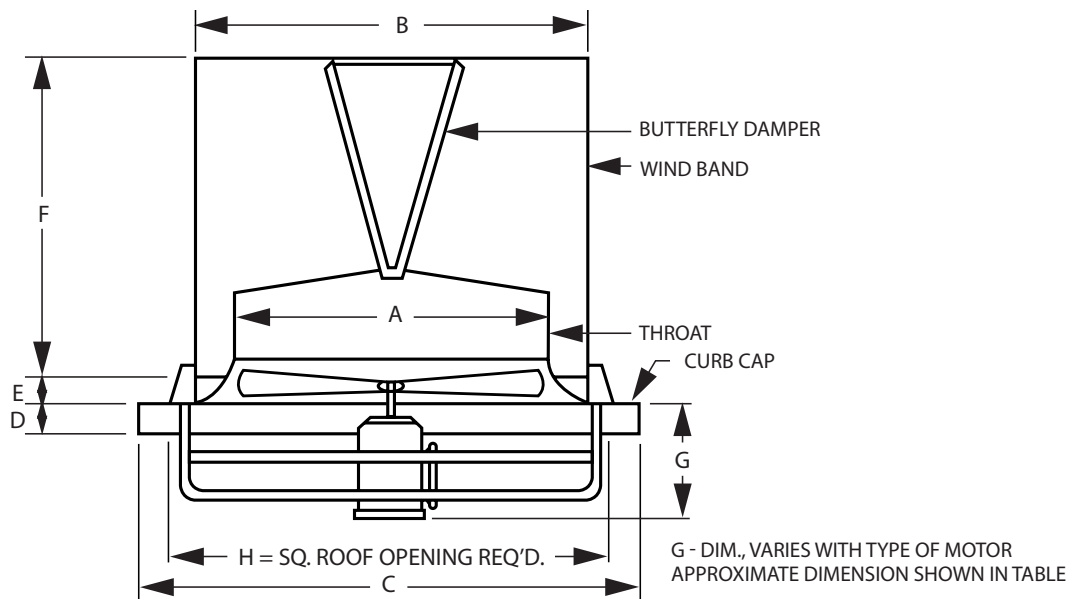

MODEL	DIMENSIONS IN INCHES*								WT (lbs) LESS MTR	MAX MTR FRAME
	A	B	C	D	E	F	G	H		
UDVL-18	19	24	33 SQ.	2.5	3	16	13	28	150	145T
UDVL-24	25	30	39 SQ.	2.5	3	19	15	34	213	184T
UDVL-30	31	36	45 SQ.	2.5	3	22	15	40	255	184T
UDVL-36	37	42	51 SQ.	2.5	3	25	18	46	305	215T
UDVL-42	43	48	57 SQ.	2.5	3	27	18	52	295	256T
UDVL-48	49	54	63 SQ.	2.5	3	30	20	58	490	256T
UDVL-60	61	66	75 SQ.	2.5	3	42	22	70	615	256T

*DO NOT USE FOR CONSTRUCTION

CONSULT FACTORY FOR CERTIFIED PRINTS

MODEL	AIRFLOW PERFORMANCE (CFM)	
	MINIMUM	MAXIMUM
UDVL-18	2,650	4,600
UDVL-24	4,715	10,500
UDVL-30	7,365	17,750
UDVL-36	10,605	22,600
UDVL-42	14,435	28,970
UDVL-48	18,765	41,000
UDVL-60	29,445	54,000

MINIMUM CFM VALUE REQUIRED TO OPEN DAMPER BLADES

UBVL BELT DRIVE UPBLAST ROOF VENTILATORS

FEATURES & BENEFITS

- Low silhouette weatherproof closure for vertical air discharge
- V-belt drive for low speed operation
- Spark resistant, cast aluminum airfoil axial impeller
- Factory set adjustable pitch impeller
- Aerodynamically efficient performance
- TEFC industrial duty motor
- Self-aligning pillow block ball bearings
- Weather-tight steel curb panel
- Heavy duty welded steel construction
- Baked polyester powder coat finish with a zinc rich primer
- Rugged galvanized damper section with butterfly damper blades
- Damper rods turn in nylon bearings and require no lubrication



APPLICATIONS

- General ventilation
- Removal of process related fumes, dust and smoke

ACCESSORIES / OPTIONS

- Pre-fabricated roof curbs
- Explosion proof & special duty motors
- Hot dipped galvanized construction
- 304 or 316 stainless steel construction
- Disconnect switches, mounted or mounted & wired
- Magnetic damper pads for positive closure
- Baked epoxy powder coat finish, two layers
- AMCA spark resistant construction - consult factory

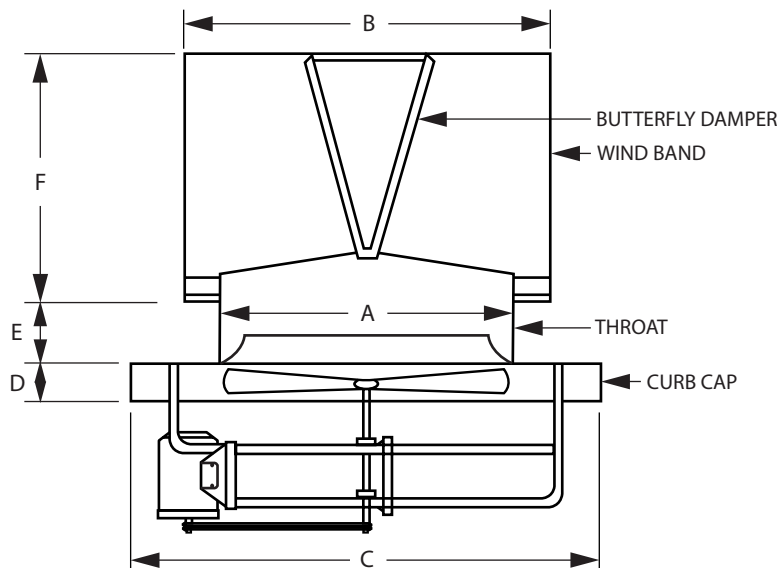

MODEL	DIMENSIONS IN INCHES*						WT (lbs) LESS MTR	MAX MTR FRAME
	A	B	C	D	E	F		
UBVL-24	25	30	39 SQ.	2.5	3	19	270	145T
UBVL-30	31	36	45 SQ.	2.5	3	22	330	145T
UBVL-36	37	42	51 SQ.	2.5	3	25	350	145T
UBVL-42	43	48	57 SQ.	2.5	3	27	413	184T
UBVL-48	49	54	63 SQ.	2.5	3	30	478	184T
UBVL-54	55	60	69 SQ.	2.5	3	36	830	184T
UBVL-60	61	66	75 SQ.	2.5	3	42	895	184T

*DO NOT USE FOR CONSTRUCTION

CONSULT FACTORY FOR CERTIFIED PRINTS

MODEL	AIRFLOW PERFORMANCE (CFM)	
	MINIMUM	MAXIMUM
UBVL-24	4,715	7,090
UBVL-30	7,365	12,473
UBVL-36	10,605	16,554
UBVL-42	14,435	23,645
UBVL-48	18,765	33,160
UBVL-54	23,850	37,458
UBVL-60	29,445	44,600

MINIMUM CFM VALUE REQUIRED TO OPEN DAMPER BLADES

ROOF VENTILATORS

UBV BELT DRIVE UPBLAST ROOF VENTILATORS

FEATURES & BENEFITS

- Standard upblast weatherproof closure for vertical air discharge
- V-belt drive for low speed operation
- Spark resistant, cast aluminum airfoil axial impeller
- Factory set adjustable pitch impeller
- TEFC motor located outside of airstream
- Adjustable motor base with self-aligning pillow block ball bearings
- Belt tube to protect sheaves and belts from air stream
- Extended lube lines
- Heavy duty welded steel construction
- Weather-tight steel curb panel
- Baked polyester powder coat finish with a zinc rich primer
- Rugged galvanized damper section with butterfly damper blades
- Damper rods turn in nylon bearings and require no lubrication



APPLICATIONS

- General ventilation
- Moisture laden air
- Removal of process related fumes, dust and smoke
- Mild contaminants in the air steam

ACCESSORIES / OPTIONS

- Pre-fabricated roof curbs
- Explosion proof & special duty motors
- Hot dipped galvanized construction
- 304 or 316 stainless steel construction
- Disconnect switches, mounted or mounted & wired
- Magnetic damper pads for positive closure
- Baked epoxy powder coat finish, two layers
- AMCA spark resistant construction - consult factory

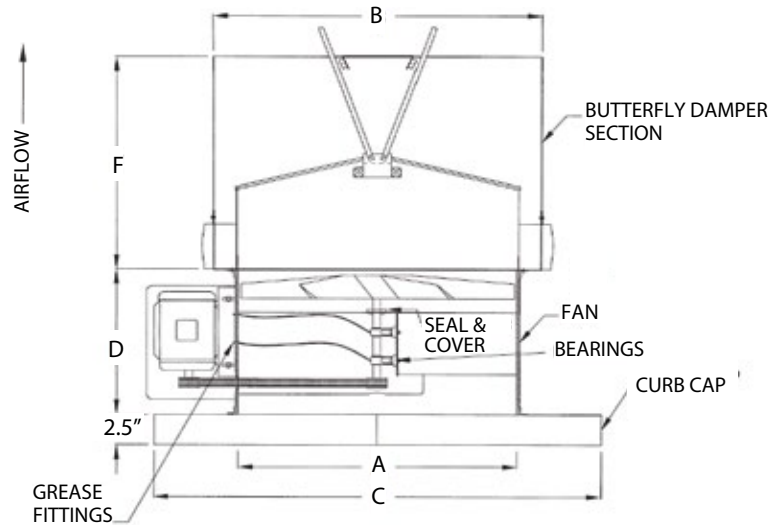

MODEL	DIMENSIONS IN INCHES*					WT (lbs) LESS MTR	MAX MTR FRAME
	A	B	C	D	F		
UBV-18	18	24	33 SQ.	18	20.0	240	145T
UBV-24	24	30	39 SQ.	18	24.0	333	182T
UBV-30	30	36	45 SQ.	18	26.0	430	184T
UBV-36	36	42	51 SQ.	18	30.5	455	213T
UBV-42	42	48	57 SQ.	22	33.0	650	215T
UBV-48	48	54	63 SQ.	24	33.5	680	215T
UBV-54	54	60	69 SQ.	30	39.5	810	215T
UBV-60	60	66	75 SQ.	30	40.0	850	254T

*DO NOT USE FOR CONSTRUCTION

CONSULT FACTORY FOR CERTIFIED PRINTS

MODEL	AIRFLOW PERFORMANCE (CFM)	
	MINIMUM	MAXIMUM
UBV-18	2,650	5,350
UBV-24	4,715	10,500
UBV-30	7,365	16,440
UBV-36	10,605	22,500
UBV-42	14,435	33,300
UBV-48	18,432	41,200
UBV-54	25,984	45,472
UBV-60	29,445	61,000

MINIMUM CFM VALUE REQUIRED TO OPEN DAMPER BLADES

HRV HOODED ROOF VENTILATORS

FEATURES & BENEFITS

- Supply or exhaust applications
- Direct drive (HRVD) or belt drive (HRVB) arrangements
- Spark resistant, cast aluminum airfoil axial impeller
- Factory set adjustable pitch impeller
- Aerodynamically efficient performance
- Heavy duty welded steel base
- Baked polyester powder coat finish with a zinc rich primer
- Hinged aluminum hood with galvanized birdscreen
- TEFC industrial duty motor
- Direct drive units are easily maintained – no belts or pulleys
- Belt drive units have self-aligning pillow block bearings
- Belt drive units use v-belt drive for low speed operation



APPLICATIONS

- General ventilation
- Heat exhaust
- Filtered air supply
- Removal of process related fumes, dust and smoke
- Make-up air

ACCESSORIES / OPTIONS

- Filtered intake unit
- Gravity shutter for exhaust only
- Pre-fabricated roof curbs
- Custom curb panel to match existing curb
- Explosion proof motors
- Special duty motors
- 2" thick disposable filters, for filtered intake unit
- Variable pitch sheaves for easy & accurate adjustment
- Disconnect switch - mounted, or mounted & wired
- Motor operated damper for supply or exhaust applications
- Baked epoxy powder coat finish, two layers
- AMCA spark resistant construction - consult factory

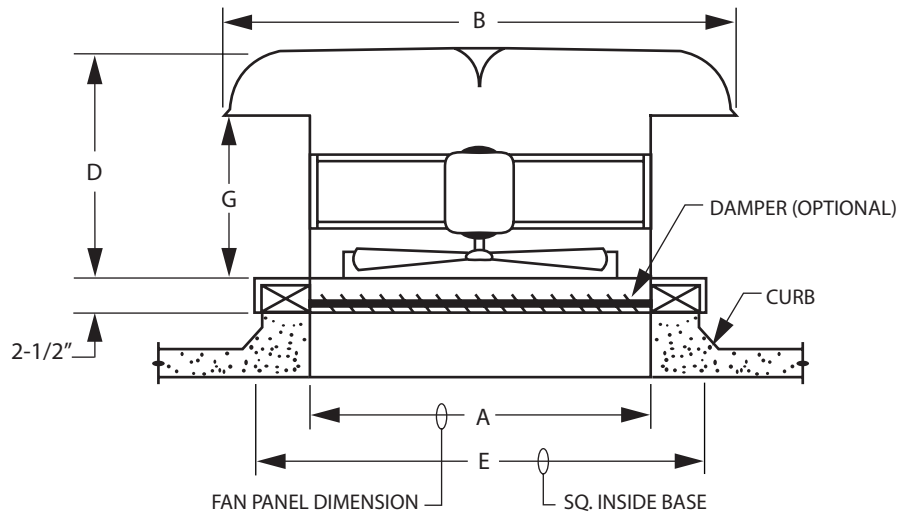

MODEL	DIMENSIONS IN INCHES*					WT (lbs) LESS MTR	MAX MTR FRAME	HP
	A	B	D	E	G			
HRV-24	30	54 x 64	41.5	39	28	324	145T	¼ - 1
HRV-30	36	60 x 76	41.5	45	28	365	145T	⅓ - 1 ½
HRV-36	42	72 x 82	45.5	51	30	410	145T	½ - 2
HRV-42	48	80 x 89	45.5	57	30	503	184T	½ - 3
HRV-48	54	87 x 95	49.5	63	32	630	184T	¾ - 5
HRV-54	60	92 x 98	50.5	69	32	870	215T	1 - 5
HRV-60	66	90 x 107	54.5	75	34	1140	215T	1 - 10

MODEL	AIRFLOW PERFORMANCE (CFM)		
	MINIMUM	MAXIMUM	MAXIMUM CFM W/FILTERS
HRV-24	800	6,700	4,875
HRV-30	800	11,800	12,000
HRV-36	1,800	15,376	14,000
HRV-42	3,300	22,296	16,000
HRV-48	4,283	30,900	18,000
HRV-54	8,000	35,238	17,500
HRV-60	9,600	47,000	32,000

*DO NOT USE FOR CONSTRUCTION

CONSULT FACTORY FOR CERTIFIED PRINTS

CENTRIFUGAL FANS & BLOWERS

TCD BC AIRFOIL BLOWERS

FEATURES & BENEFITS

- Direct drive, non-overloading 'TEK' impeller
- Highly efficient airfoil (BCA) design
- Epoxy coated steel housing
- Flanged and drilled outlet, ABS inlet cone
- Rugged GRP (polyamide) impeller
- Single or three phase TEFC motors
- CW rotation; rotatable to 5 positions
- Capacities to 4,500 cfm



ACCESSORIES / OPTIONS

- Backdraft damper
- Weather hood
- Gravity shutter
- Inlet flanges & guards
- Shaft seal
- Drain w/plug
- Special duty motors
- CCW rotation

AIRFLOW PERFORMANCE (CFM) AT 1750 RPM

MODEL	MTR HP	dBA @5'	0" SP		.5" SP		1" SP		1.5" SP		2" SP		2.5" SP		3" SP		3.5" SP	
			CFM	BHP	CFM	BHP	CFM	BHP	CFM	BHP	CFM	BHP	CFM	BHP	CFM	BHP	CFM	BHP
TCD250	¼	58	840	0.08	670	0.09	440	0.08	-	-	-	-	-	-	-	-	-	-
TCD280	¼	62	1130	0.18	1030	0.18	770	0.18	350	0.16	-	-	-	-	-	-	-	-
TCD315	½	67	1650	0.33	1480	0.33	1290	0.34	1010	0.33	570	0.28	-	-	-	-	-	-
TCD355	¾	72	2320	0.63	2110	0.64	1900	0.65	1630	0.64	1300	0.63	720	0.57	-	-	-	-
TCD400	1½	73	3070	1.20	2880	1.21	2650	1.22	2410	1.23	2140	1.22	1790	1.21	1240	1.17	-	-
TCD450	2	74	4490	1.75	4320	1.77	4080	1.80	3780	1.81	3460	1.82	3080	1.80	2660	1.77	2160	1.69

AIRFLOW PERFORMANCE (CFM) AT 3450 RPM

MODEL	MTR HP	dBA @5'	0" SP		1" SP		2" SP		3" SP		4" SP		5" SP		6" SP		7" SP	
			CFM	BHP	CFM	BHP	CFM	BHP	CFM	BHP	CFM	BHP	CFM	BHP	CFM	BHP	CFM	BHP
TCD200	⅓	68	870	0.24	700	0.24	500	0.21	275	0.17	-	-	-	-	-	-	-	-
TCD225	½	73	1060	0.42	950	0.43	780	0.44	580	0.42	-	-	-	-	-	-	-	-
TCD250	¾	75	1625	0.64	1520	0.65	1320	0.66	1110	0.66	870	0.64	440	0.53	-	-	-	-
TCD280	1½	77	2220	1.35	2170	1.37	2000	1.39	1760	1.41	1480	1.40	1150	1.34	560	1.13	-	-
TCD315	3	82	3330	2.48	3160	2.52	2960	2.53	2740	2.55	2500	2.57	2230	2.58	1910	2.53	1480	2.34
TCD355	5	86	4574	4.83	4412	4.75	4324	4.83	4180	4.67	4060	4.67	3553	4.60	3230	4.53	2850	4.37

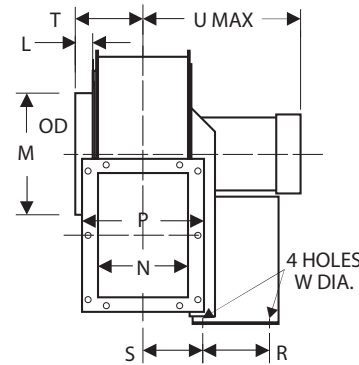
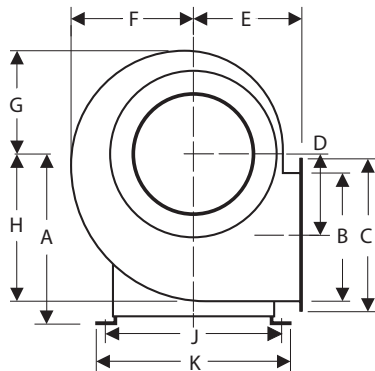

DIMENSIONS IN INCHES*

MODEL	A	B	C	D	E	F	G	H	J	K	L	M	N	P	R	S	T	U MAX	W	WT (lbs) LESS MTR
TCD200	10.5	7.1	9.5	4.7	6.8	7.2	6.1	8.6	11.5	13.0	1.5	7.0	5.3	7.7	5.5	3.7	4.3	11.1	0.5	43
TCD225	11.5	7.9	10.2	5.6	7.5	8.3	6.9	9.9	12.5	14.0	1.5	8.0	6.1	8.5	5.5	4.1	4.7	12.9	0.5	51
TCD250	12.5	8.7	11.0	6.4	8.2	9.1	7.6	11.1	13.5	15.0	1.5	9.0	6.9	9.3	5.5	4.5	5.1	13.3	0.5	56
TCD280	14.0	10.2	12.6	6.7	8.9	10.1	8.5	12.2	14.5	16.0	1.5	10.0	7.7	10.0	8.0	4.9	5.5	13.7	0.5	69
TCD315	15.5	11.8	14.2	7.6	9.8	11.3	9.6	13.8	17.5	19.5	2.0	12.0	8.5	10.8	10.0	5.6	6.6	16.1	0.6	114
TCD355	17.5	13.4	15.8	8.4	10.7	12.6	10.6	15.4	19.0	21.0	2.0	14.0	9.5	11.8	12.0	6.1	7.1	14.6	0.6	120
TCD400	19.5	15.2	18.3	9.3	11.8	14.1	11.9	17.2	21.0	23.0	2.0	16.0	10.6	13.8	12.0	6.7	7.7	15.7	0.6	147
TCD450	21.5	16.9	20.1	10.5	13.2	16.0	13.3	19.3	23.0	25.0	2.0	18.0	11.8	15.0	12.0	7.3	8.3	17.8	0.6	181

*DO NOT USE FOR CONSTRUCTION

CONSULT FACTORY FOR CERTIFIED PRINTS

TFD FLANGE MOUNT BLOWERS

FEATURES & BENEFITS

- Direct drive, non-overloading 'TEK' impeller
- Highly efficient airfoil (BCA) design
- Epoxy coated steel housing
- Flanged and drilled outlet, ABS inlet cone
- Rugged GRP (polyamide) airfoil impeller
- Single or three phase TEFC motors
- CW rotation rotatable to any position
- Capacities to 4,500 cfm



ACCESSORIES / OPTIONS

- Inlet filter
- Inlet flanges & guards
- CCW rotation
- Gravity shutter
- Shaft seal

AIRFLOW PERFORMANCE (CFM) AT 1750 RPM																		
MODEL	MTR HP	dBA @5'	0" SP		.5" SP		1" SP		1.5" SP		2" SP		2.5" SP		3" SP		3.5" SP	
			CFM	BHP	CFM	BHP	CFM	BHP	CFM	BHP	CFM	BHP	CFM	BHP	CFM	BHP	CFM	BHP
TFD250	¼	58	840	0.1	670	0.1	440	0.1	-	-	-	-	-	-	-	-	-	-
TFD280	¼	62	1130	0.2	1030	0.2	770	0.2	350	0.2	-	-	-	-	-	-	-	-
TFD315	½	67	1650	0.3	1480	0.3	1290	0.3	1010	0.3	570	0.3	-	-	-	-	-	-
TFD355	¾	72	2320	0.6	2110	0.6	1900	0.7	1630	0.6	1300	0.6	720	0.6	-	-	-	-
TFD400	1½	73	3070	1.2	2880	1.2	2650	1.2	2410	1.2	2140	1.2	1790	1.2	1240	1.2	-	-
TFD450	2	74	4490	1.8	4320	1.8	4080	1.8	3780	1.8	3460	1.8	3080	1.8	2660	1.8	2160	1.7

AIRFLOW PERFORMANCE (CFM) AT 3450 RPM																		
MODEL	MTR HP	dBA @5'	0" SP		1" SP		2" SP		3" SP		4" SP		5" SP		6" SP		7" SP	
			CFM	BHP	CFM	BHP	CFM	BHP	CFM	BHP	CFM	BHP	CFM	BHP	CFM	BHP	CFM	BHP
TFD200	¼	68	870	0.2	700	0.2	500	0.2	275	0.2	-	-	-	-	-	-	-	-
TFD225	½	73	1060	0.4	950	0.4	780	0.4	580	0.4	-	-	-	-	-	-	-	-
TFD250	¾	75	1625	0.6	1520	0.7	1320	0.7	1110	0.7	870	0.6	440	0.5	-	-	-	-
TFD280	1½	77	2220	1.4	2170	1.4	2000	1.4	1760	1.4	1480	1.4	1150	1.3	560	1.1	-	-
TFD315	3	82	3330	2.5	3160	2.5	2960	2.5	2740	2.6	2500	2.6	2230	2.6	1910	2.5	1480	2.3

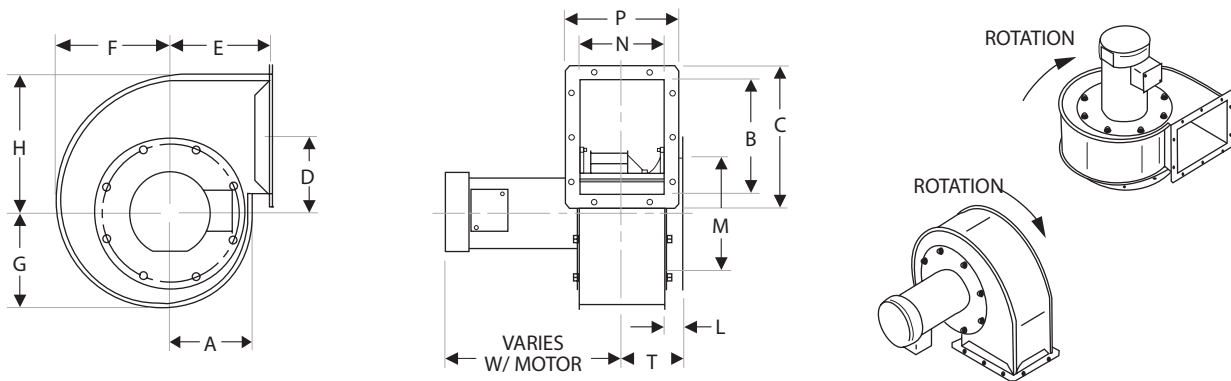

DIMENSIONS IN INCHES*													
MODEL	A	B	C	D	E	F	G	H	L	M	N	P	T
TFD200	5.4	6.9	9.5	4.9	6.8	7.3	6.1	8.8	1.6	7.0	5.2	7.7	4.3
TFD225	6.0	7.7	10.2	5.6	7.5	8.2	6.8	9.9	1.6	8.0	5.9	8.5	4.7
TFD250	6.6	8.7	11.0	6.1	8.2	9.0	7.5	10.9	1.7	9.0	6.9	9.3	5.2
TFD280	7.4	10.1	12.6	6.8	8.9	10.1	8.4	12.2	1.7	10.0	7.5	10.0	5.5
TFD315	8.2	11.7	14.2	7.5	9.8	11.3	9.3	13.7	2.2	12.0	8.3	10.8	6.4
TFD355	9.2	13.3	15.8	8.4	10.7	12.7	10.5	15.4	2.2	14.0	9.3	11.8	6.9
TFD400	10.4	15.1	18.3	9.2	11.8	14.1	11.8	17.1	2.2	16.0	10.4	13.8	7.5
TFD450	11.7	16.8	20.1	10.6	13.2	15.9	13.1	19.3	2.2	18.0	11.5	15.0	8.1

*DO NOT USE FOR CONSTRUCTION

CONSULT FACTORY FOR CERTIFIED PRINTS

CENTRIFUGAL FANS & BLOWERS

CPB CAST ALUMINUM PRESSURE BLOWERS

FEATURES & BENEFITS

- Cast aluminum radial blade impeller
- Designed for highly efficient performance
- AMCA Type B spark resistant construction
- Rugged cast aluminum housing
- Circular inlet & outlet collars
- Single or three phase TEFC motors
- CW or CCW rotation available; please specify
- Discharge rotatable to 4 positions
- Suitable for 0 to 150 F
- Static pressures to 11" w.g.
- Capacities to 3,410 cfm



APPLICATIONS

- Vehicle exhaust
- Air knives
- Combustion air
- Exhausting smoke, fumes & dust from high pressure applications
- Dust collection & material conveying
- High pressure cooling & drying

ACCESSORIES / OPTIONS

- Inlet filter
- Inlet & outlet guards
- Protective coating
- Nozzle
- Slide gate damper
- Flanged inlet & outlet
- Teflon shaft seal for corrosive environments
- Explosion proof motors
- Special duty motors

MODEL	HP	WHEEL DIA.	INLET	OUTLET	ROTATION	AIRFLOW PERFORMANCE (CFM) AT 3450 RPM											
						1.0" SP		3.0" SP		5.0" SP		7.0" SP		9.0" SP		11.0" SP	
						CFM	BHP	CFM	BHP	CFM	BHP	CFM	BHP	CFM	BHP	CFM	BHP
CPB-08-12	½	8.0 x 2.8	4	4	CW	345	0.37	242	0.31	-	-	-	-	-	-	-	-
CPB-09-12	½	8.0 x 2.8	5	4	CCW	380	0.39	275	0.30	-	-	-	-	-	-	-	-
CPB-09-34	¾	9.0 x 2.9	5	4	CCW	480	0.62	380	0.57	210	0.42	-	-	-	-	-	-
CPB-09-01	1	10.5 x 2.9	5	4	CCW	575	0.80	495	0.72	400	0.54	270	0.41	-	-	-	-
CPB-10-34	¾	9.0 x 2.9	6	5	CW, CCW	571	0.73	400	0.60	91	0.37	-	-	-	-	-	-
CPB-10-32	1½	11.0 x 2.8	6	5	CW, CCW	840	1.50	700	1.35	590	1.26	460	1.05	-	-	-	-
CPB-12-01	1	11.0 x 3.0BC	7	6	CW	865	1.07	710	0.99	535	0.87	160	0.55	-	-	-	-
CPB-12-32	1½	10.5 x 2.9	7	6	CW, CCW	1055	1.62	890	1.42	670	1.20	360	0.77	-	-	-	-
CPB-12-02	2	11.0 x 2.8	7	6	CW, CCW	1150	1.91	975	1.72	750	1.40	475	1.05	-	-	-	-
CPB-12-3A	3	11.5 x 2.8	7	6	CW, CCW	1245	2.48	1086	2.20	890	2.00	630	1.53	-	-	-	-
CPB-12-3B	3	12.8 x 2.9	7	6	CW, CCW	Contact Factory		1237	3.10	1046	2.81	882	2.50	700	1.91	-	-
CPB-12-05	5	14.0 x 3.0	7	6	CW, CCW	1600	4.21	1550	4.00	1400	3.78	1285	3.63	1125	3.40	945	2.81
CPB-14-03	3	12.3 x 3.0	8	6	CW, CCW	1575	3.40	1405	3.11	1250	2.71	1000	2.21	685	1.90	-	-
CPB-14-05	5	14.0 x 3.0	8	6	CW, CCW	1875	4.98	1710	4.60	1550	4.15	1400	3.80	1203	3.50	1045	2.98
CPB-15-05	5	14.0 x 3.0	8	8	CW, CCW	2300	5.30	2100	4.95	1900	4.50	1678	4.10	1410	3.60	1170	3.21
CPB-15-07	7½	15.5 x 5.0BC	8	8	CW	2360	6.50	2210	6.00	1950	5.32	1800	4.65	1595	4.10	1300	3.70
CPB-15-10A	10	15.5 x 5.0	8	8	CW, CCW	2700	9.40	2510	8.90	2365	7.95	2211	7.00	1950	6.20	1711	5.90
CPB-15-10B	10	16.5 x 5.0	8	8	CW, CCW	3000	11.00	2875	10.70	2700	10.40	2550	10.20	2400	9.90	2215	9.40
CPB-15-15A	15	14.0 x 3.0	10	8	CCW	2565	6.20	2347	5.80	2175	5.30	1841	4.60	1586	4.00	1181	3.20
CPB-15-15B	15	15.5 x 5.0BC	10	8	CW	2610	7.10	2420	6.50	2210	6.00	1975	5.50	1712	4.95	1425	4.10
CPB-15-15C	15	15.5 x 5.0	10	8	CCW	3211	11.20	3108	10.90	2875	10.40	2743	9.70	2501	8.60	2184	7.00
CPB-15-15D	15	16.5 x 5.0	10	8	CCW	3410	14.00	3230	13.00	3029	12.20	2850	11.60	2669	10.80	2561	10.20

CPB CAST ALUMINUM PRESSURE BLOWERS

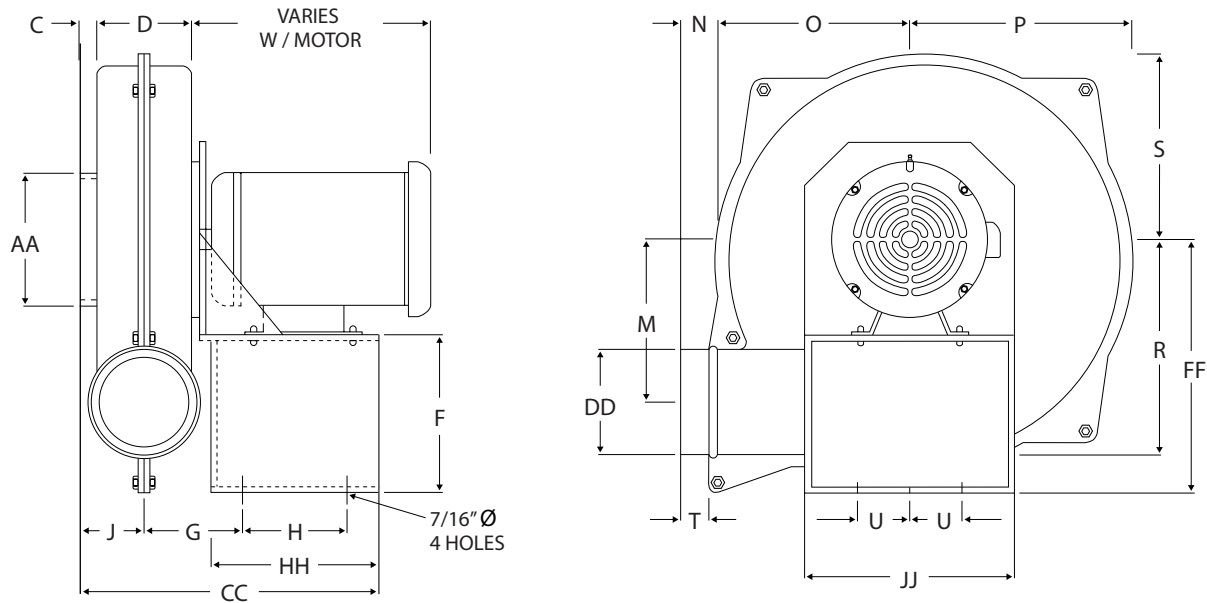

CLOCKWISE ROTATION - BOTTOM HORIZONTAL DISCHARGE SHOWN ABOVE

DIMENSIONS IN INCHES*

MODEL	C	D	F	G	H	J	M	N	O	P	R	S	T	U	AA	CC	DD	FF	HH	JJ	MTR FRAME
CPB-08	1.3	3.8	6.0	4.3	5.5	3.1	4.1	1.4	4.5	5.3	6.3	4.8	1.0	3.5	4.0	14.0	4.0	9.5	7.9	9.5	56
CPB-09	1.3	3.8	6.0	4.3	5.5	3.1	5.6	1.4	5.9	7.0	7.8	6.4	1.0	3.5	5.0	14.0	4.0	9.5	7.9	9.5	56 143T-145T
CPB-10	1.3	4.3	7.0	4.5	5.5	3.4	6.5	1.0	6.9	9.4	9.0	7.8	1.0	3.5	6.0	14.5	5.0	10.5	7.9	7.0	56
	1.3	4.3	7.0	4.5	5.5	3.4	6.5	1.0	6.9	9.4	9.0	7.8	1.0	3.5	6.0	14.5	5.0	10.5	7.9	9.0	143T-145T
CPB-12	1.3	4.3	8.0	4.5	5.5	3.4	7.4	1.1	7.6	9.1	10.2	7.6	1.0	3.5	7.0	14.5	6.0	11.5	7.9	9.5	56 143T-145T
CPB-12	1.3	4.3	7.0	4.9	8.8	3.4	7.4	1.1	7.6	9.1	10.2	7.6	1.0	4.9	7.0	18.3	6.0	11.5	11.4	12.5	182T-184T
CPB-14	1.6	5.3	9.5	5.3	5.5	4.1	8.0	1.0	8.6	9.9	11.3	9.5	1.0	3.5	8.0	15.0	6.0	13.0	7.9	9.5	143T-145T
	1.6	5.3	8.5	5.9	8.8	4.1	8.0	1.0	8.6	9.9	11.3	9.5	1.0	4.9	8.0	18.5	6.0	13.0	11.4	12.5	182T-184T
CPB-15	1.4	6.0	9.0	6.0	8.8	4.4	8.0	1.8	9.4	10.9	11.9	9.9	1.0	4.9	8.0	20.4	8.0	13.5	11.4	12.5	143T-145T 182T-184T
CPB-15	1.4	6.0	9.0	6.0	8.8	4.4	8.0	1.8	9.4	10.9	11.9	9.9	1.0	4.9	8.0	20.4	8.0	14.5	11.4	12.5	213T-215T 254T-256T
CPB-15	1.4	6.0	9.0	6.0	8.8	4.4	8.0	1.8	9.4	10.9	11.9	9.9	1.0	4.9	10.0	20.1	8.0	13.5	11.4	12.5	182T-184T
	1.4	6.0	9.0	6.0	8.8	4.4	8.0	1.8	9.4	10.9	11.9	9.9	1.0	4.9	10.0	20.1	8.0	14.5	11.4	13.5	213T-215T

*DO NOT USE FOR CONSTRUCTION

CONSULT FACTORY FOR CERTIFIED PRINTS

CENTRIFUGAL FANS & BLOWERS

CAB CAST ALUMINUM BLOWERS

FEATURES & BENEFITS

- Forward curved, steel impeller
- Designed for highly efficient performance
- Rugged cast aluminum housing, heavy duty steel base
- AMCA Type C spark resistant construction
- CW rotation only; rotatable to 4 positions
- Suitable for 0 to 150 F
- Circular inlet and outlet collars
- Single or three phase TEFC motors
- Capacities to 1,550 cfm

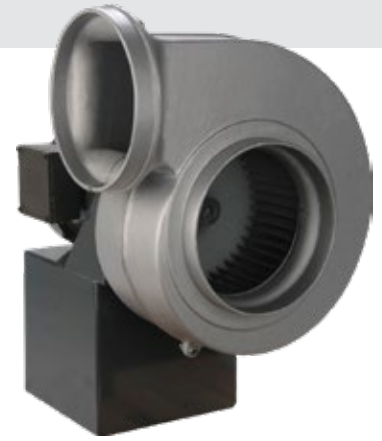

APPLICATIONS

- Smoke & fume removal
- Spot cooling
- Electronic equipment & DC motor cooling

ACCESSORIES / OPTIONS

- Inlet filter
- Inlet & outlet guards
- Flanged inlet & outlet
- Protective coating
- Nozzle
- Carrying handle
- Explosion proof motors
- Special duty motors
- Slide gate damper
- Support base with rubber feet
- Teflon shaft seal for corrosive environments
- Wall mounting bracket

		AIRFLOW PERFORMANCE (CFM)																				
MODEL	MAX HP	RPM	0.25" SP		0.5" SP		0.75" SP		1" SP		1.5" SP		2.0" SP		2.5" SP		3.0" SP		3.5" SP		4.0" SP	
			CFM	BHP	CFM	BHP	CFM	BHP	CFM	BHP	CFM	BHP	CFM	BHP	CFM	BHP	CFM	BHP	CFM	BHP	CFM	BHP
CAB-04	1/3	1725	210	0.04	135	0.02	-	-	-	-	-	-	-	-	-	-	-	-	-	-	-	-
	1/3	3450	500	0.38	470	0.34	440	0.32	420	0.30	360	0.26	260	0.16	-	-	-	-	-	-	-	-
CAB-06	1/4	1150	248	0.06	96	0.02	-	-	-	-	-	-	-	-	-	-	-	-	-	-	-	-
	1/3	1725	440	0.18	370	0.14	300	0.11	-	-	-	-	-	-	-	-	-	-	-	-	-	-
	1 1/2	3450	900	1.45	870	1.40	850	1.35	820	1.30	780	1.20	730	1.15	660	1.00	580	0.90	470	0.80	390	0.70
CAB-08	1/4	1150	860	0.26	720	0.18	600	0.15	-	-	-	-	-	-	-	-	-	-	-	-	-	-
	1 1/2	1725	1550	1.15	1500	1.05	1490	1.00	1400	0.90	1200	0.85	950	0.70	-	-	-	-	-	-	-	-

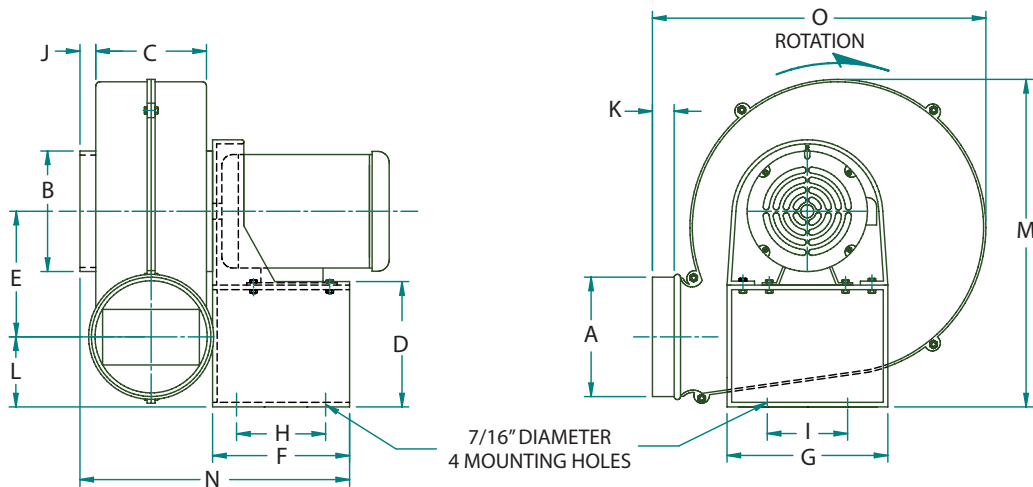

DIMENSIONS IN INCHES*																
MODEL	WHEEL DIA.	A	B	C	D	E	F	G	H	I	J	K	L	M	N	O
CAB-04	4.75	4.0	4.9	4.0	5.0	2.8	7.0	6.9	4.3	4.3	0.9	0.9	5.8	12.5	13.1	9.1
CAB-06	6.25	6.0	5.9	4.6	5.0	4.3	7.0	6.9	4.3	4.3	1.1	0.9	4.3	13.5	14.3	11.8
CAB-08	8.50	8.0	7.9	5.8	8.0	5.4	8.5	8.4	6.5	6.5	1.1	0.9	5.6	17.9	16.6	14.0

*DO NOT USE FOR CONSTRUCTION. ALL DIMENSIONS SHOWN +/- 0.125".

CONSULT FACTORY FOR CERTIFIED PRINTS

TEK PLUG FANS

FEATURES & BENEFITS

- High efficiency, backward curved airfoil impeller
- Injection molded GRP polyamide TEK impeller
- Modular construction, compact design
- OEM custom configurations available
- Horizontal and vertical applications
- Non-overloading power characteristics
- TEFC face mounted motors
- Supply and return air applications

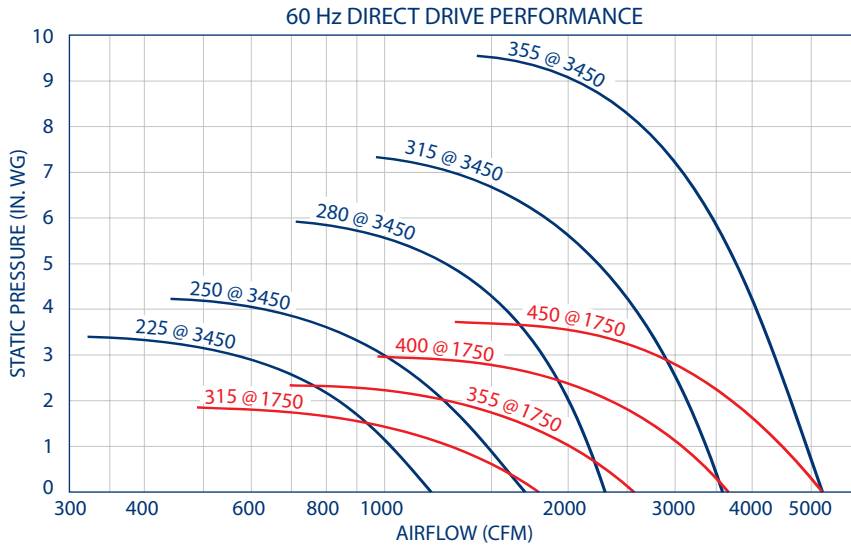

MOTOR CHART		
MODEL	RPM	MTR HP
TEK225H-V2	3450	½
TEK250H-V2	3450	¾
TEK280H-V2	3450	1 ½
TEK315H-V4	1750	½
TEK315H-V2	3450	3
TEK355H-V4	1750	¾
TEK355H-V2	3450	5
TEK400H-V4	1750	1 ½
TEK450H-V4	1750	2

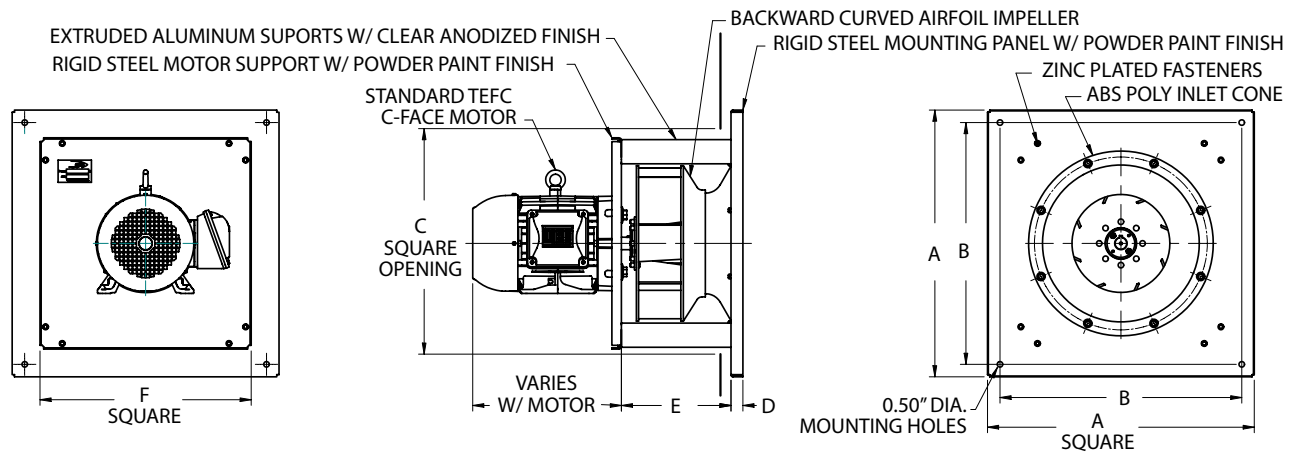

MODEL	DIMENSIONS IN INCHES*						
	A	B	C	D	E	F	
TEK225H-V2	20.0	17.8	14.0	1.1	6.4	13.0	
TEK250H-V2	20.0	17.8	15.0	1.1	7.1	14.0	
TEK280H-V2	20.0	17.8	16.0	1.1	7.9	15.0	
TEK315H-V4	24.0	21.8	17.5	1.1	8.6	17.0	
TEK315H-V2	24.0	21.8	17.5	1.1	8.6	17.0	
TEK355H-V4	24.0	21.8	19.5	1.1	9.5	19.0	
TEK355H-V2	24.0	21.8	19.5	1.1	9.5	19.0	
TEK400H-V4	28.0	25.8	20.5	1.1	10.5	20.0	
TEK450H-V4	28.0	25.8	24.0	1.1	11.7	23.6	

*DO NOT USE FOR CONSTRUCTION

CONSULT FACTORY FOR CERTIFIED PRINTS

PLUG & PLENUM FANS

TEK-ECM PLENUM FANS

FEATURES & BENEFITS

- IE5 efficiency, electronically commutated (EC) motor
- Plug-and-play integrated motor and drive
- Bluetooth communication available
- High efficiency, backward curved airfoil impeller
- Injection molded GRP polyamide TEK impeller
- OEM custom configurations available
- Non-overloading power characteristics
- Ideal for variable speed applications
- Available in 6 sizes up to 10,000 cfm

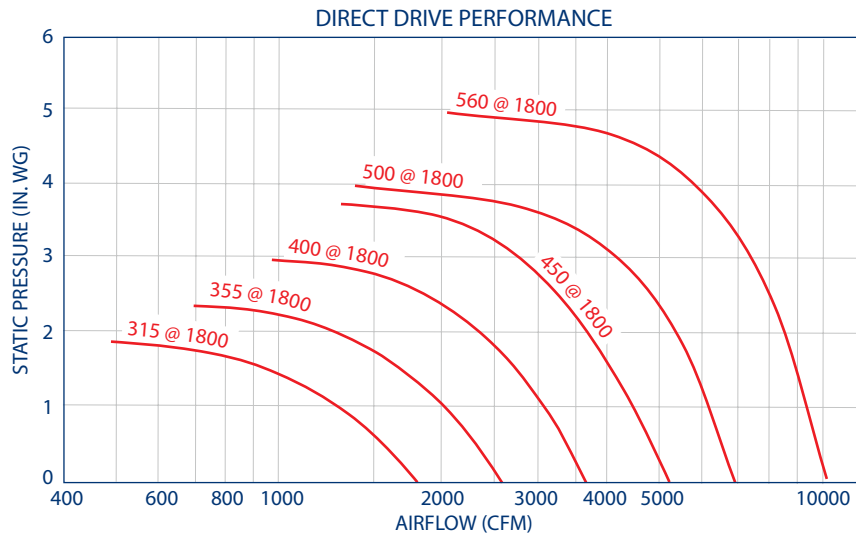

EC MOTOR CHART		
MODEL	RPM	ECM HP
TEK315H-H4-ECM	1800	½
TEK355H-H4-ECM	1800	¾
TEK400H-H4-ECM	1800	1 ½
TEK450H-H4-ECM	1800	2
TEK500H-H4-ECM*	1800	5
TEK560H-H4-ECM*	1800	7 ½

*CCW ROTATION ONLY FOR MODELS
TEK500H-H4-ECM & TEK560H-H4-ECM

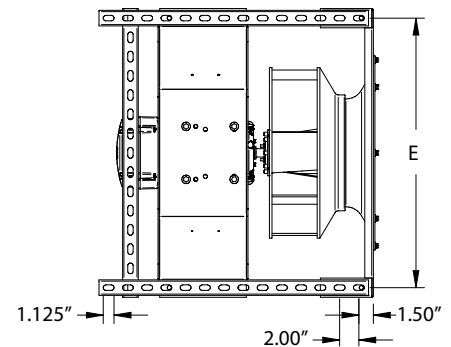
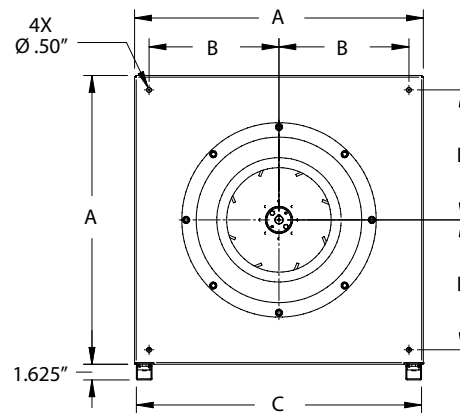
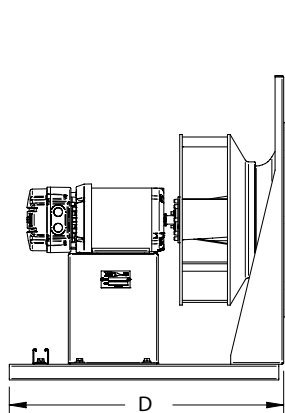

MODEL	DIMENSIONS IN INCHES*				
	A	B	C	D	E
TEK315H-H4-ECM	20.00	9.00	19.62	22.50	18.00
TEK355H-H4-ECM	20.00	9.00	19.62	22.50	18.00
TEK400H-H4-ECM	30.00	13.50	29.62	28.50	28.00
TEK450H-H4-ECM	30.00	13.50	29.62	28.50	28.00
TEK500H-H4-ECM	30.00	13.50	29.62	28.50	28.00
TEK560H-H4-ECM	30.00	13.50	29.62	28.50	28.00

*DO NOT USE FOR CONSTRUCTION

CONSULT FACTORY FOR CERTIFIED PRINTS

TEK PLENUM FANS

FEATURES & BENEFITS

- High efficiency, backward curved airfoil impeller
- Injection molded GRP polyamide TEK impeller
- Modular construction, compact design
- OEM custom configurations available
- Suitable for horizontal applications
- Non-overloading power characteristics
- TEFC industrial duty motors
- Supply and return air applications

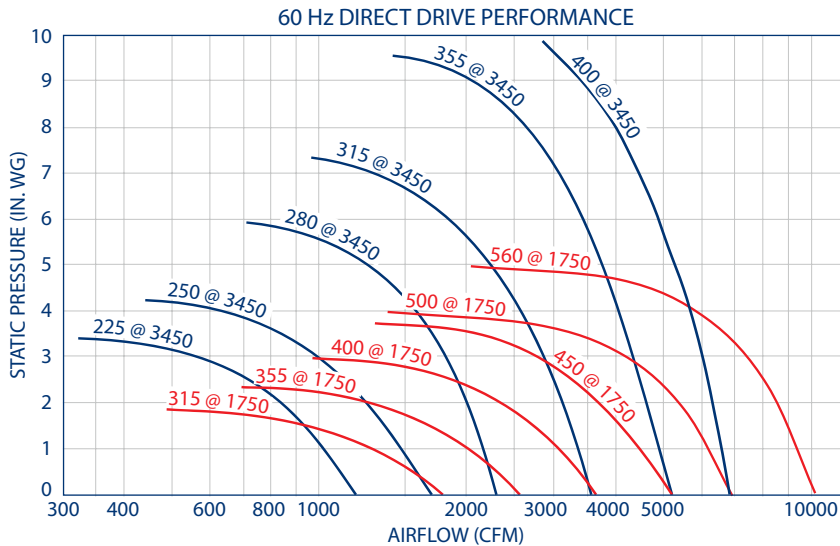

MOTOR CHART		
MODEL	RPM	MTR HP
TEK225H-H2	3450	½
TEK250H-H2	3450	¾
TEK280H-H2	3450	1 ½
TEK315H-H4	1750	½
TEK315H-H2	3450	3
TEK355H-H4	1750	¾
TEK355H-H2	3450	5
TEK400H-H4	1750	1 ½
TEK400H-H2	3450	7 ½
TEK450H-H4	1750	2
TEK500H-H4*	1750	5
TEK560H-H4*	1750	7 ½

*CCW ROTATION ONLY FOR MODELS TEK500H & TEK560H

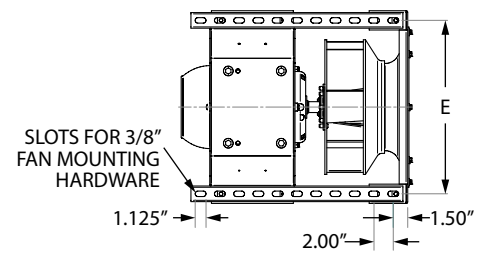
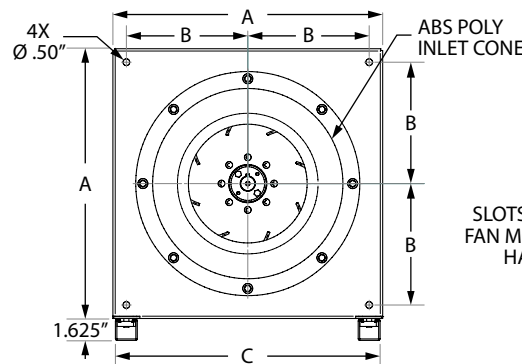
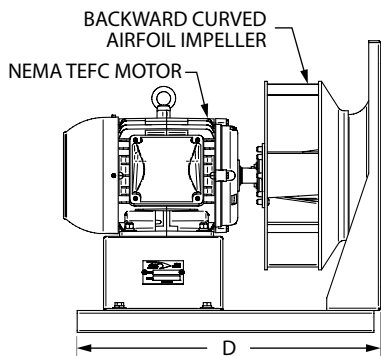

DIMENSIONS IN INCHES*

MODEL	A	B	C	D	E
TEK225H-H2	20.00	9.00	19.62	22.50	18.00
TEK250H-H2	20.00	9.00	19.62	22.50	18.00
TEK280H-H2	20.00	9.00	19.62	22.50	18.00
TEK315H-H4	20.00	9.00	19.62	22.50	18.00
TEK315H-H2	20.00	9.00	19.62	22.50	18.00
TEK355H-H4	20.00	9.00	19.62	22.50	18.00
TEK355H-H2	20.00	9.00	19.62	22.50	18.00
TEK400H-H4	30.00	13.50	29.62	28.50	28.00
TEK400H-H2	30.00	13.50	29.62	28.50	28.00
TEK450H-H4	30.00	13.50	29.62	28.50	28.00
TEK500H-H4	30.00	13.50	29.62	28.50	28.00
TEK560H-H4	30.00	13.50	29.62	28.50	28.00

*DO NOT USE FOR CONSTRUCTION

CONSULT FACTORY FOR CERTIFIED PRINTS

OEM & REPLACEMENT IMPELLERS

TEK CENTRIFUGAL BC AIRFOIL IMPELLERS

FEATURES & BENEFITS

- Backward curved airfoil (BCA) impeller
- Non-overloading power characteristics
- Aerodynamic perfection; computer-aided design
- Super quiet, highly efficient performance
- Injection molded from high strength GRP polyamide
- Stronger than steel with half the weight
- Permissible ambient temperature range: -22 F to 176 F
- Stocked in nine sizes: 7" through 18" diameter
- CW, CCW, or DWDI; matching inlet cones

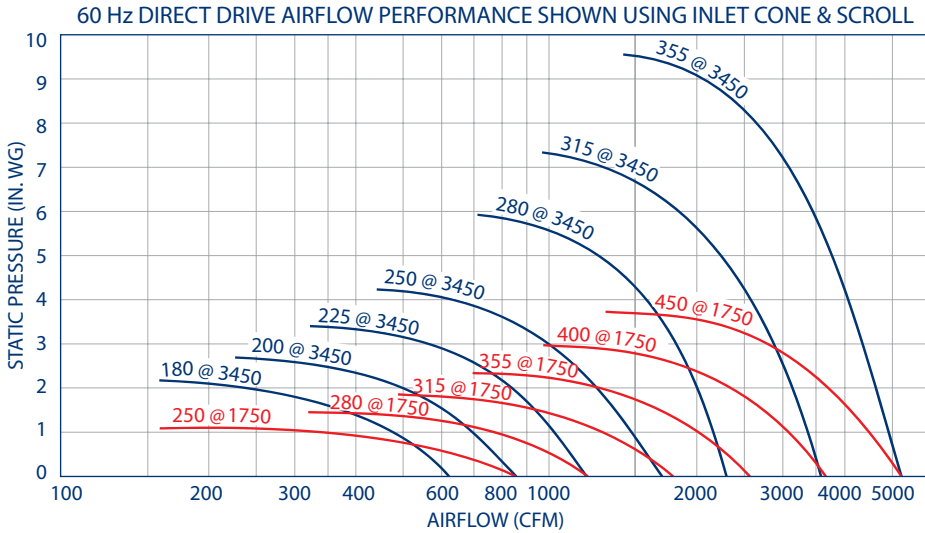

IMPELLER PERFORMANCE		
MODEL	RPM	MAX HP
TEK180	3450	0.15
TEK200	3450	0.25
TEK225	3450	0.43
TEK250	1750	0.10
	3450	0.75
TEK280	1750	0.20
	3450	1.50
TEK315	1750	0.35
	3450	2.65
TEK355	1750	0.63
	3450	5.00
TEK400	1750	1.10
TEK450	1750	2.00

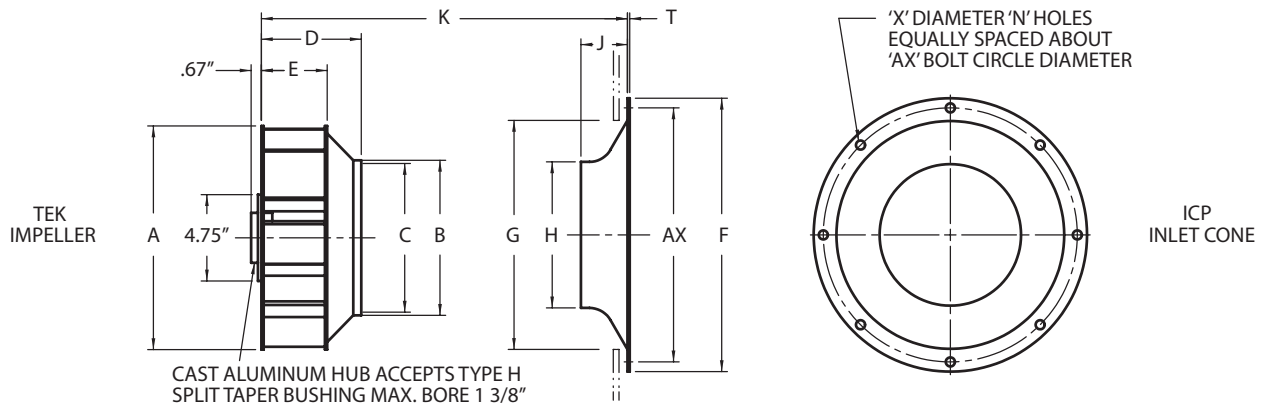

MODEL	DIMENSIONS IN INCHES*														
	A	B	C	D	E	F	G	H	J	K	N	T	X	AX	WT (lbs)
TEK180	7.1	4.9	4.7	3.3	2.1	8.5	7.2	4.5	1.5	4.5	6	0.1	0.4	8.0	1.2
TEK200	7.9	5.5	5.3	3.5	2.3	9.8	8.0	5.0	1.6	4.9	6	0.1	0.4	9.1	1.6
TEK225	8.8	6.1	5.8	4.1	2.6	11.0	8.9	5.7	1.8	5.6	6	0.1	0.4	10.1	1.8
TEK250	9.8	6.8	6.5	4.5	2.9	12.0	10.0	6.3	2.1	6.2	6	0.1	0.4	11.1	2.0
TEK280	11.0	7.6	7.4	5.0	3.3	13.7	11.4	7.1	2.3	7.0	6	0.1	0.5	12.6	2.8
TEK315	12.3	8.5	8.2	5.5	3.5	15.0	12.6	8.0	2.6	7.7	6	0.1	0.5	14.0	3.8
TEK355	14.0	9.6	9.3	6.4	4.3	16.6	14.2	9.0	2.9	8.6	8	0.1	0.5	15.6	5.2
TEK400	15.6	10.6	10.2	6.9	4.5	18.3	16.0	9.8	3.3	9.6	8	0.2	0.5	17.3	7.0
TEK450	17.7	12.1	11.6	7.7	5.1	20.2	17.3	11.2	3.7	10.8	8	0.2	0.5	19.3	8.0

*DO NOT USE FOR CONSTRUCTION

CONSULT FACTORY FOR CERTIFIED PRINTS

AXIAL AIRFOIL IMPELLERS

FEATURES & BENEFITS

- Airfoil design, modular construction, adjustable pitch
- Superior performance and sound characteristics
- Pressure cast aluminum hub and blades
- GRP (polypropylene) blades available
- Advanced computer selection program
- Permissible ambient temperature range for aluminum impellers: -40 F to 250 F
- Permissible ambient temperature range for GRP impellers: -40 F to 176 F
- Custom diameters from 12" to 79"
- Ideal for OEM use or as replacement impellers
- Capacities to 200,000 cfm from stock components

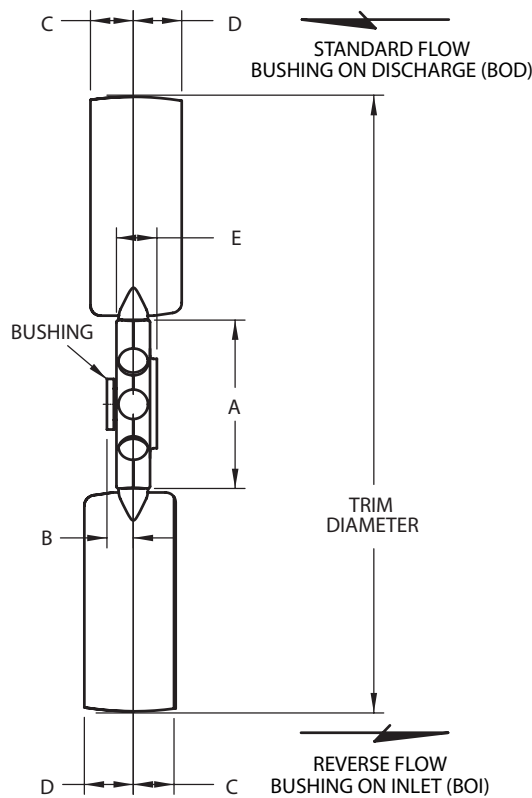
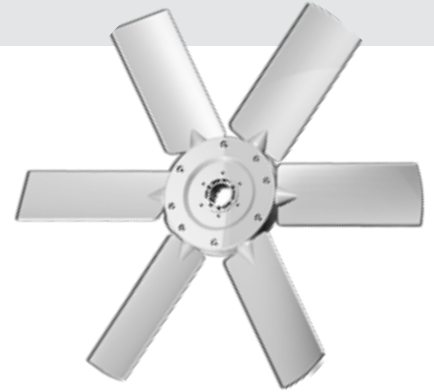

					DIMENSIONS IN INCHES*							
RANGE	HUB TYPE	NO. OF BLADES	BUSHING TYPE	ROTATION	MAX BORE	DIAMETER		A	B	C	D	E
						MIN	MAX					
1000	150	5, 10	H	CW/CCW	1 1/2	12.0	35.4	5.9	0.9	1.0	1.5	1.4
1400	255	3, 4, 6	P1	CW	1 3/4	24.0	51.0	10.0	1.3	1.6	2.4	2.1
1400	350/352	3, 4, 6, 12	Q1	CW	2 11/16	27.0	55.0	13.8	1.9	1.6	2.4	2.1
2000	400	3, 6, 9	Q2	CW	2 5/8	39.0	72.8	15.7	2.1	2.2	3.4	3.5
2000	550	3, 4, 6, 12	R2	CW	3 5/8	39.0	78.7	21.7	2.6	2.2	3.4	3.5
1100	131	3, 6	G	CW/CCW	1	12.0	34.6	5.2	0.9	1.1	1.6	1.6
1100	181	3, 6, 9	H	CW/CCW	1 1/2	15.8	36.8	7.1	0.9	1.1	1.6	1.6
1100	251	3, 6, 9, 12	P1	CW/CCW	1 3/4	21.0	39.5	9.9	1.3	1.1	1.6	1.8

*DO NOT USE FOR CONSTRUCTION

CONSULT FACTORY FOR CERTIFIED PRINTS

HVLS FANS

CMX HVLS FANS

FEATURES & BENEFITS

- High efficiency EC brushless motor, continuous duty operation
- Robust steel structure for long life
- Virtually silent, 5-blade aluminum airfoils
- Corrosion resistant, anodized aluminum airfoil design
- Plastic, aerodynamically-shaped blade terminals
- Optimized performance and acoustic comfort
- Security wire, stabilizing cables and hub ring for safety
- 200-240Vac or 400-480Vac, 50/60 Hz, 3 phase operation
- Speed controllable
- Maintenance-free, gearless motor
- Maximum permissible ambient temperature: 120 F
- Integrated EMC (electromagnetic interference) filters
- Easily clean with low pressure water jets



ACCESSORIES

- Downrod (32" standard)
- Z purlin brackets
- I-beam mounting kit
- Glulam mounting kit
- Potentiometer speed control
- Smart touch controller

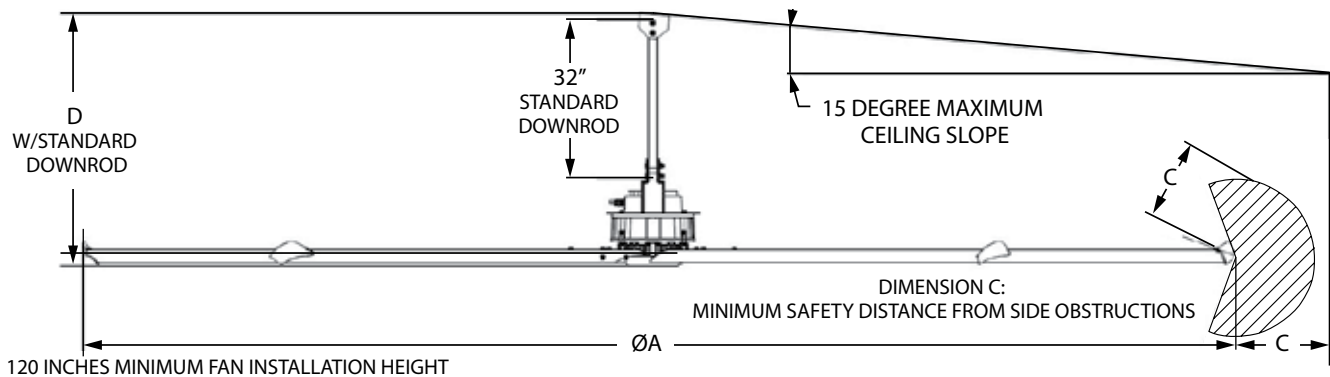

MODEL	PERFORMANCE					
	MAX RPM	MAX SERVICED DIA. (ft)	dba ⁽¹⁾	HP	MAX CURRENT (amps)	MINIMUM CIRCUIT SIZE
CMX-10	130	98	55	1.1	3.8	10A@200-240V, 3Ø 10A@400-480V, 3Ø
CMX-12	85	117	52	0.8	2.6	
CMX-14	80	136	55	0.9	2.7	
CMX-16	70	156	56	1.1	3.5	
CMX-18	63	176	49	1.2	3.6	
CMX-20	55	195	50	1.2	3.7	
CMX-24	51	234	55	1.6	4.8	

DIMENSIONS			
ØA (ft)	C (ft)	D (in.)	WT (lbs)
10	1.2	49	176
12	1.5	49	194
14	1.5	50	220
16	1.8	50	234
18	1.8	51	249
20	1.8	51	260
24	1.8	51	282

@240V/60Hz supply, max speed

⁽¹⁾Sound testing taken with the sensor 1.5 m above the floor and 6 m from the center of the fan at 5 m high, measured in a laboratory environment. Actual results in field conditions may vary due to sound reflecting surfaces and environmental conditions.

*DO NOT USE FOR CONSTRUCTION
CONSULT FACTORY FOR CERTIFIED PRINTS

NFPA 13 Standards for HVLS Fans

- Maximum allowable fan diameter of 24 feet.
- Fans must be approximately centered between four adjacent sprinklers.
- There must be a 3 foot minimum clearance from the sprinkler deflector to the fan.
- Fans must be interlocked to shut down immediately upon receiving a water flow signal from the fire alarm system.

DSF DESTRATIFICATION FANS

FEATURES & BENEFITS

- Reduce hot & cold spots through the mixing of air in large spaces
- Lower energy costs, increased comfort
- Ideal for any building with ceilings 15' or higher
- Breaks up stratification layers
- Powerful, axial flow fan
- External rotor motor design results in superior motor cooling and durability
- Speed controllable using optional solid state speed control
- Permanently lubricated ball bearing motors for maintenance-free operation
- Automatic reset, thermal overload protection
- 120V, 60 Hz operation
- Steel housing with corrosion resistant finish
- Gripple fasteners supplied for safe mounting
- Rotating mounting bracket permits mounting at any angle
- Maximum permissible ambient temperature: 140 F
- Capacities to 1,460 cfm; available in 10", 12" and 14" fan sizes

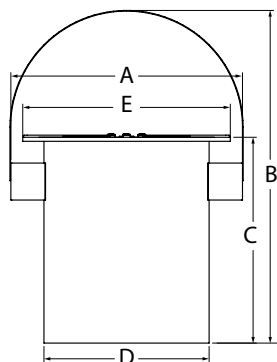

How Do I Determine How Many Fans I Need?

Air circulation should occur once or twice per hour to maintain a healthy building environment. Select the fan cfm based on the following ceiling height recommendations:

- 15 ft - 20 ft use 420 cfm fan or model DSF250
- 20 ft - 25 ft use 1055 cfm fan or model DSF300
- 25 ft - up use 1460 cfm fan or model DSF350

To determine the number of DSF fans for a given area, the following information is required:

- $(L \times W \times H) =$ Size of room
- $\text{Size of room} / \text{cfm} / 60 =$ Number of units

Example: a building is 125 ft long, 75 ft wide, and 20 ft high.

- $125 \times 75 \times 20 = 187,500$ cu. ft
- $187,500 \text{ cu. ft} / 1055 \text{ cfm (DSF300 Fan)} / 60 = 3$ DSF Fans (round to the nearest whole number)

MODEL	DIMENSIONS IN INCHES*				
	A	B	C	D	E
DSF250	15.2	20.2	15.2	10.2	13.4
DSF300	17.3	23.9	17.9	12.2	15.4
DSF350	19.2	27.3	20.3	14.2	17.4

*DO NOT USE FOR CONSTRUCTION

				FAN PERFORMANCE											
MAX WATTS	MAX AMPS	RPM	0" SP CFM	AIR VELOCITY DEPENDING ON DISTANCE FROM DSF FAN, FPM											
				3 ft	6 ft	10 ft	13 ft	15 ft	20 ft	23 ft	25 ft	30 ft	33 ft	35 ft	
60	0.51	1700	420	378	270	220	156	90	60	20	-	-	-	-	
94	0.80	1675	1055	918	594	380	234	162	120	79	38	20	-	-	
162	1.38	1685	1460	1100	756	760	468	324	300	217	169	120	59	19	

CONSULT FACTORY FOR CERTIFIED PRINTS

DSF & CMX FAN APPLICATIONS

Commercial

- Gymnasiums
- Big box stores
- Showrooms
- Schools



Industrial

- Warehouses
- Distribution centers
- Airport hangars
- Cold storage

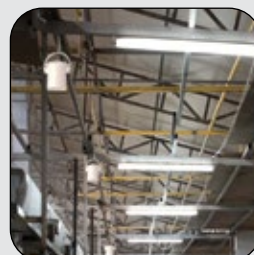
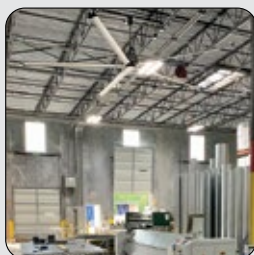

Agriculture

- Dairy barns
- Greenhouses
- Horse stables
- Produce farms

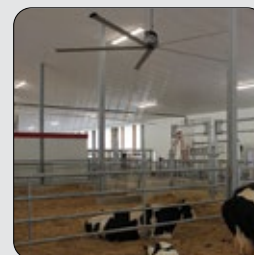

DAMPERS

IRIS DAMPERS

FEATURES & BENEFITS

- Precise airflow measurement, reduced field labor time
- Single station measurement and control
- Accurate air balancing to +/- 5% in straight duct
- Compact design, superior performance
- Fitted EPDM gasket for airtight mounting
- Fully retractable blades for duct cleaning
- Ideal for office buildings, pharmaceuticals, clean rooms & laboratories
- Available in 4" to 32" sizes; capacities to 20,000 cfm
- Max operating temperature:
 - 180 F continuous
 - 250 F intermittent

IRIS DAMPER

- Hot dipped galvanized steel construction

POSITIVE SEAL CONSTRUCTION (OPTIONAL)

Some applications may require a fully closed damper. For those requiring a 100% shutoff, a positive seal option is available on sizes 4" through 12", in both galvanized and stainless steel IRIS dampers.

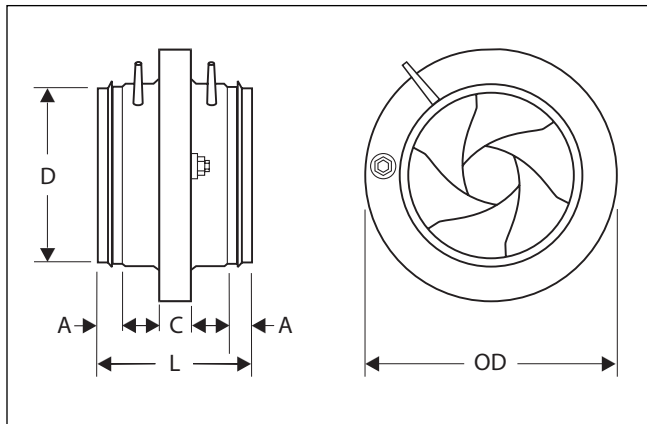

IRIS-S DAMPER

- AISI 316 stainless steel construction
- Prolonged excellence in extreme conditions
- Ideal for corrosive environments

SIMPLE OPERATION

Using a pressure gauge and a damper's Airflow Adjustment Chart, desired airflow in a duct can be attained by simply turning the damper adjustment nut until the required pressure drop is reached (Fig. 1).

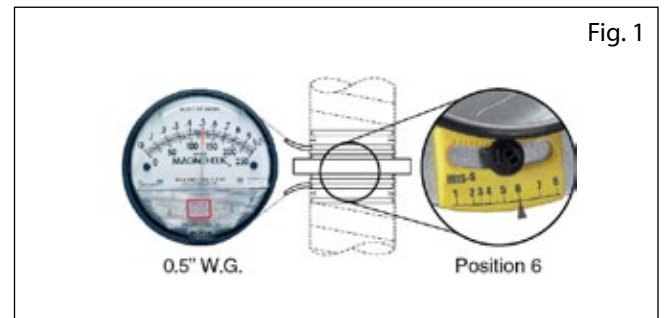

DIMENSIONS IN INCHES*						
MODEL	A	C	D	L	OD	WT (lbs)
IRIS-04, IRIS-S-04	1.2	0.6	3.9	4.6	6.5	1.1
IRIS-05, IRIS-S-05	1.2	0.6	4.9	4.6	7.4	1.5
IRIS-06, IRIS-S-06	1.2	0.6	5.9	4.6	9.1	2.0
IRIS-08, IRIS-S-08	1.2	0.6	7.8	4.6	11.2	3.1
IRIS-10, IRIS-S-10	1.6	0.7	9.8	5.3	13.2	4.6
IRIS-12, IRIS-S-12	1.6	0.7	11.8	6.1	16.1	7.7
IRIS-16, IRIS-S-16	2.4	0.8	15.7	7.5	20.7	14.1
IRIS-20, IRIS-S-20	2.0	0.8	19.6	6.7	25.8	21.2
IRIS-25, IRIS-S-25	2.0	0.9	24.7	6.7	32.1	34.4
IRIS-32, IRIS-S-32	3.9	0.9	31.4	10.6	40.0	55.1

*DO NOT USE FOR CONSTRUCTION
CONSULT FACTORY FOR CERTIFIED PRINTS

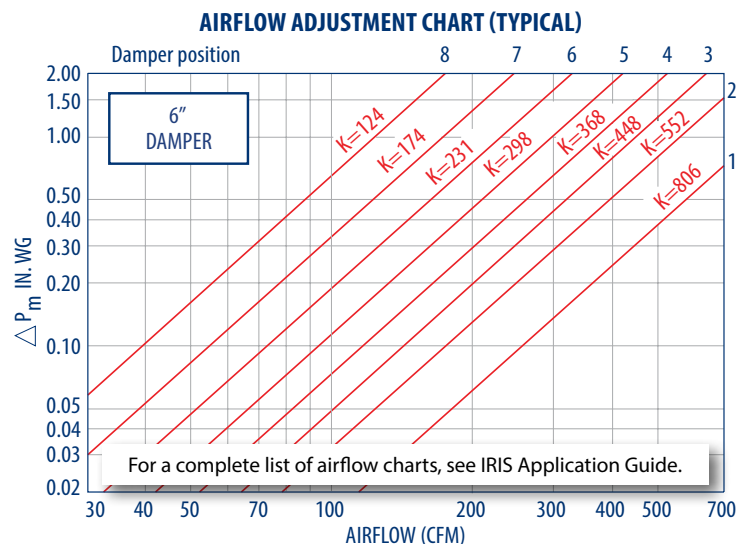

CUSTOMIZED APPLICATIONS

At Continental Fan, *better AIRFLOW by DESIGN* is not just a slogan — it is a fact. Continental Fan's engineering department designs custom fans and delivers 3D models. Nearly all Continental Fan's industrial products can be customized for specific applications.

CUSTOMIZED ADD TUBEAXIAL FANS

These model ADD direct drive tubeaxial fans are designed for use on offshore oil well platforms and can withstand the ocean's harsh environment.

SPECIAL FEATURES

- Continuously welded construction
- Hot dip galvanized coating
- Cast aluminum impeller
- Swivel yoke
- OSHA style front and rear guards
- TEFC motor with arctic duty grease



CUSTOMIZED AIB TUBEAXIAL FANS

Laboratories offer the most challenging fan applications. The problem is moist, corrosive, hot air. Continental Fan's answer is this all stainless steel belt driven tubeaxial fan.

SPECIAL FEATURES

- 316L stainless steel construction
- 316L stainless steel impeller
- High temperature construction to 375 F
- Continuously welded construction
- Horizontal mounting brackets
- Severe duty motor



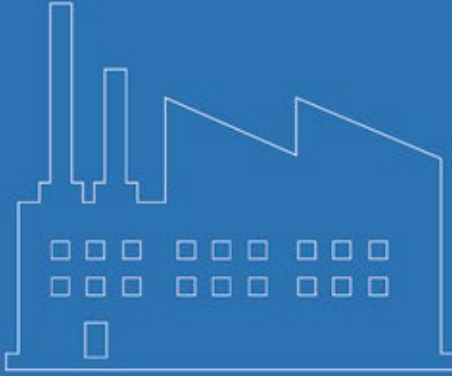

***Industrial Fans
& Blowers***



***OEM Solutions
& Custom Fans***



***Commercial Fans
& Dampers***



***Residential Fans &
Air Purifiers***



Industrial Fans & Blowers

Continental Fan Manufacturing Inc.
Buffalo, NY ~ Dayton, OH

Continental Fan Canada Inc.
Mississauga, ON

continentalfan.com
1-800-779-4021

Distributed by:

