



Wholesale Ventilation Products



better AIRFLOW by DESIGN™



HISTORY, DEDICATION, AND EXPERIENCE

Continental Fan was established in 1986 to manufacture and distribute quality ventilation equipment. Our objectives then were simple ... to provide superior products, dependable service, competitive pricing, and a knowledgeable staff to satisfy our customers' needs. They remain unchanged today.

Industry leading air moving equipment has earned an excellent reputation through years of exceptional performance and reliable operation. We offer the largest quick ship program available and fast deliveries for those products not in stock.

Our experienced and friendly staff delivers customer service that is second to none. We are happy to entertain inquiries for custom fans and provide our customers with 3D models for their air moving solutions. In short, we provide ... *better AIRFLOW by DESIGN™*

TABLE OF CONTENTS

ENERGY RECOVERY VENTILATORS

- [ECO-FLO^{Plus} Energy Recovery Ventilator \(ERV\)](#) 3

DUCT FANS

- [AXC In-Line Duct Fans](#) 4
- [AXS EC In-Line Duct Fans](#) 5
- [AXP In-Line Duct Fans](#) 6
- [MFT & MFT-S Mixed Flow In-Line Fans](#) 7
- [MBI Centrifugal In-Line Fans](#) 8
- [EXM External Mount Duct Fans](#) 9

RADON FANS

- [ARI-C Radon Fans](#) 10

DRYER BOOSTER FANS

- [DVK Dryer Booster Fan](#) 11

BATHROOM FANS & KITS

- [AXC Bathroom Ventilation Kits](#) 12
- [TF100-EC Tranquil Bathroom Fan](#) 13
- [TF140-EC Tranquil Bathroom Fan](#) 14
- [TF140-DC Tranquil Bathroom Fan](#) 15
- [TF Tranquil Bathroom Fans](#) 16
- [TF400 Tranquil Bathroom Fan](#) 17
- [CEF Ceiling Exhaust Fans](#) 18

AIR PURIFIERS

- [CX1000 Portable Air Purifier](#) 19
- [CX-Pro In-Duct Air Purifier](#) 20
- [CX-Aire In-Duct Air Purifier](#) 21

DAMPERS

- [BDD Backdraft Dampers](#) 22
- [IRIS Dampers](#) 23

ACCESSORIES, GRILLES & CONTROLS

- [Accessories](#) 24
- [Grilles](#) 25
- [Controls](#) 25

HVLS FANS

- [CMX HVLS Fans](#) 26

DESTRATIFICATION FANS

- [DSF Destratification Fans](#) 27

WALL FANS

- [SEF Shutter Mount Wall Fans](#) 28
- [PEF Panel Mount Wall Fans](#) 28
- [GEF Guard Mount Wall Fans](#) 28

ROOF & WALL EXHAUST FANS

- [RMD Direct Drive Axial Exhaust Fans](#) 29
- [CDD Direct Drive Downblast Fans](#) 30
- [CUD Direct Drive Upblast Fans](#) 31

OEM AND INDUSTRIAL FANS & BLOWERS

- [OEM / Industrial Fans & Blowers](#) 33

CFM SELECT

For latest pricing and fan selection, create an account at cfmselect.com.



TERMS & CONDITIONS OF SALE

For terms & conditions of sale, visit continentalfan.com.



ECO-FLO^{Plus} ENERGY RECOVERY VENTILATOR (ERV)



ECO-FLO^{Plus} ERV is the all-in-one ventilation solution for new construction and renovation projects. This compact ventilator is capable of exhausting stale indoor air and supplying fresh filtered outdoor air. The heat recovered from the exhaust air will pre-heat or pre-cool the incoming supply air (depending on the season). ECO-FLO^{Plus} has the added benefit of indoor humidity control.

Features & Benefits

- Supplies fresh outdoor air and exhausts stale indoor air
- CO2 sensor monitors real-time concentration and dilutes CO2 concentration with fresh air
- Quiet operation (less than 32.7dB(A))
- Low energy demand 11.5 watts
- Easily control from the app, remote, or ventilator casing
- Reversible 3-speed axial fan with an energy efficient DC motor
- High-tech ceramic energy regenerator with heat recovery efficiency up to 97%
- Air purification with a pre-filter and MERV11 (F7) filter
- Built-in temperature sensor
- Automatic shutter prevents backdrafts
- Plain white interior panel
- Simple through-the-wall installation
- Frost and condensation free
- Flexible operation, working individually or in groups

See ECO-FLO^{Plus} catalog for more information

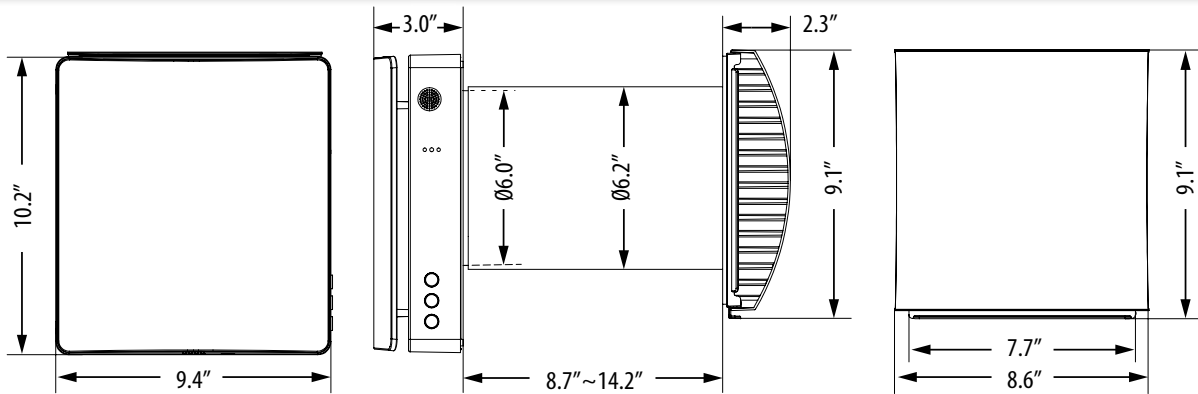

Consult factory for walls thicker or thinner than the standard dimensions.

PERFORMANCE

MODEL	THERMAL RECOVERY		SPEED	WATTS	AMPS	AIRFLOW (CFM) ¹		AIRFLOW (CFM) ² (BOOST MODE MAX)	RPM (MAX)	SOUND PRESSURE (dBA)	POWER SUPPLY
	Up to 97%					(with F7 Filter)	(without F7 Filter)				
ECO-FLO ^{Plus}		LOW	9.7	0.14	11.8	20.0	35	2200	32.7	100V~240V AC 50-60Hz	
		MED	10.7	0.15	23.5	33.0					
		HIGH	11.5	0.16	29.4	41.2					

1. AIRFLOW IN SUPPLY/EXHAUST MODE
2. MAX AIRFLOW UNDER FAN BOOST MODE

IP X4 INGRESS PROTECTION



1. Ventilation unit	4. Ceramic energy regenerator	7. Mounting plate	9. Temperature sensor
2. MERV 11 (F7) filter	5. 12V DC fan	8. Air duct	10. Exterior grille
3. Pre-filter	6. Separation ring		

AXC IN-LINE DUCT FANS



AXC In-Line Duct Fans are designed for residential, commercial and light industrial ventilation applications. The quiet, efficient backward-curved motorized impeller is capable of developing significant pressure, and the in-line configuration simplifies installation.

Features & Benefits

- Heavy gauge, drawn steel housing with baked epoxy finish
- 120V operation, other voltages available
- Easy to install - mounting brackets included
- May be mounted in any position
- Fans may be used to supply or exhaust air
- Suitable for air temperatures up to 140 F / 60 C
- Energy efficient - speed controllable (optional solid state speed control)
- Optional pre-wired with 120V power cord (AXC-C)
- Exceptionally quiet and efficient BC centrifugal motorized impeller
- External rotor motor design results in superior motor cooling and durability
- Permanently lubricated ball bearing motor for maintenance-free operation
- Automatic reset thermal overload protection
- Fan and motor are precision balanced for quiet and vibration-free operation
- Easily accessible, external junction box with pre-wired capacitor
- Available to fit duct sizes 4" - 12"; airflow capacities to 970 cfm

Accessories & Controls ~ pages 24-25

MODEL	WATTS	RPM	AIRFLOW PERFORMANCE (CFM)								
			0" SP	0.2" SP	0.4" SP	0.6" SP	0.8" SP	1.0" SP	1.2" SP	1.5" SP	2.0" SP
AXC100A-ES	43.3	2580	147	130	107	82	57	34	11		
AXC100B	83.4	2620	150	140	127	112	94	74	53	23	
AXC125A-ES	44.4	2520	179	150	121	87	49	14			
AXC125B	85.4	2750	183	160	141	122	101	77	51	14	
AXC150A-ES	46.8	2390	235	190	148	97	44				
AXC150B-ES	89.2	2450	308	260	216	175	139	108	81	47	
AXC200A-ES	84.5	2500	368	300	234	184	149	114	70		
AXC200B-ES	188	2550	579	520	453	387	329	282	245	206	154
AXC250-ES	198	2470	616	550	488	431	379	330	286	227	143
AXC300A-ES	206	2450	780	700	595	420	330	290	255	210	132
AXC300B-ES	312	2780	970	910	803	680	559	453	367	273	164

FOR PRE-WIRED WITH 120V POWER CORD, ADD -C TO MODEL.

MODEL	DIMENSIONS IN INCHES*				SHIP WT (lbs)
	ØD	Ød	A	B	
AXC100A-ES	9.5	3.9	1.0	8.3	7.5
AXC100B	9.5	3.9	1.0	8.3	8.0
AXC125A-ES	9.5	4.8	1.0	8.3	7.5
AXC125B	9.5	4.8	1.0	8.3	7.5
AXC150A-ES	9.5	5.8	1.0	8.3	7.5
AXC150B-ES	13.2	5.8	1.0	9.1	12.5
AXC200A-ES	13.2	7.8	1.0	9.1	12.0
AXC200B-ES	13.2	7.8	1.0	9.1	15.0
AXC250-ES	13.2	9.8	1.0	9.1	15.0
AXC300A-ES	15.9	11.8	1.2	11.8	18.0
AXC300B-ES	15.9	11.8	1.2	11.8	18.0

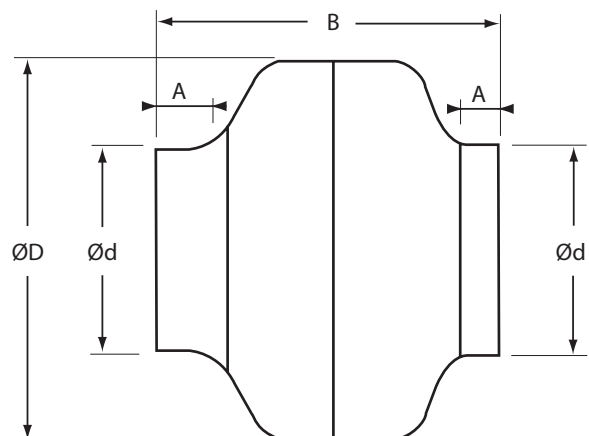

*DO NOT USE FOR CONSTRUCTION CONSULT FACTORY FOR CERTIFIED PRINTS



AXS EC IN-LINE DUCT FANS

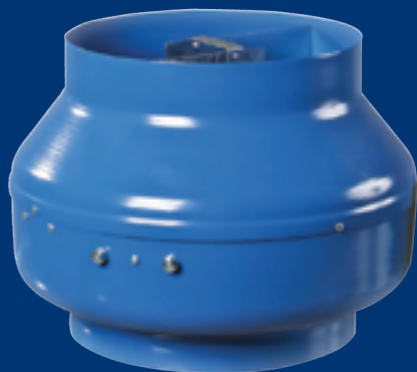

With its efficient electronically commutated (EC) motorized impeller, AXS EC In-Line Duct Fans set new standards for efficiency and versatility. The efficient backward-curved impeller can develop significant pressure. AXS EC fans are suitable for residential, commercial and light industrial ventilation applications.

Features & Benefits

- Efficient electronically commutated (EC) motorized impeller
- Energy efficient
- Corrosion resistant, durable steel housing with polymer coating
- 120V, 60 Hz operation; single phase
- Easy to install - mounting brackets included
- Suitable for air temperatures up to 105 F
- Optional pre-wired with 120V power cord (AXS-EC-C)
- Speed controllable 0-10 V
- External rotor motor design results in superior motor cooling
- Rated for continuous operation
- Permanently lubricated ball bearing motor for maintenance-free operation
- Automatic reset thermal overload protection
- Fan and motor are precision balanced for quiet, vibration-free operation
- Available to fit duct sizes 4" -12"
- Airflow capacities to 801 cfm

Accessories & Controls ~ pages 24-25

MODEL	WATTS	RPM	AIRFLOW PERFORMANCE (CFM)										
			0" SP	0.125" SP	0.2" SP	0.25" SP	0.375" SP	0.5" SP	0.75" SP	1.0" SP	1.25" SP	1.5" SP	2.5" SP
AXS100-EC	33.0	2760	151	141	135	130	120	110	90	70	49	29	
AXS125-EC	57.1	3396	248	239	231	225	211	198	170	143	115	88	
AXS150-EC	75.1	3336	306	299	291	285	272	258	231	204	176	149	40
AXS200-EC	99.0	2820	539	510	494	484	458	432	380	328	277	225	18
AXS250-EC	133.6	2628	667	600	586	577	553	530	484	438	392	346	161
AXS300-EC	173.5	2796	801	741	726	716	690	665	614	563	512	461	257

WATTS ARE INDICATED AT 100% SPEED FOR PRE-WIRED WITH 120V POWER CORD, ADD -C TO MODEL.

MODEL	DIMENSIONS IN INCHES*										SHIP WT (lbs)
	DUCT DIA.	ØD	Ød	A	B	C	E	F	G	H	
AXS100-EC	4"	10.0	3.9	13.4	12.2	10.6	8.0	0.8	1.0	1.2	7.0
AXS125-EC	5"	10.0	4.8	13.4	12.2	10.6	8.0	0.8	1.0	1.2	6.8
AXS150-EC	6"	12.0	5.8	14.2	14.2	12.6	7.9	0.8	1.0	1.2	8.2
AXS200-EC	8"	13.6	7.8	17.1	15.6	14.0	9.6	1.0	1.2	1.6	11.2
AXS250-EC	10"	13.6	9.8	17.1	15.6	14.0	9.8	1.0	1.2	1.6	12.8
AXS300-EC	12"	15.9	11.9	18.3	17.9	16.3	10.2	1.2	1.2	1.6	15.8

*DO NOT USE FOR CONSTRUCTION

CONSULT FACTORY FOR CERTIFIED PRINTS

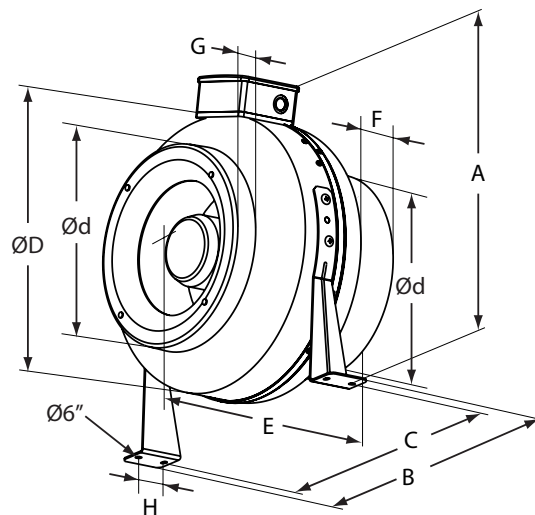

DUCT FANS

AXP IN-LINE DUCT FANS



AXP In-Line Duct Fans are designed for residential, commercial and light industrial ventilation applications. The quiet, efficient backward-curved motorized impeller is capable of developing significant pressure, and the in-line configuration simplifies installation.

Features & Benefits

- UV and corrosion resistant, durable plastic housing
- 120V operation, other voltages available
- Easy to install - mounting brackets included
- May be mounted in any position
- Fans may be used to supply or exhaust air
- Suitable for air temperatures up to 122 F
- Energy efficient - speed controllable (optional solid state speed control)
- Optional pre-wired with 120V power cord (AXP-C)
- Exceptionally quiet and efficient BC centrifugal motorized impeller
- External rotor motor design results in superior motor cooling and durability
- Permanently lubricated ball bearing motor for maintenance-free operation
- Automatic reset thermal overload protection
- Fan and motor are precision balanced for quiet, vibration-free operation
- Easily accessible, external junction box with pre-wired capacitor
- Available to fit duct sizes 4" - 12"; airflow capacities to 837 cfm

Accessories & Controls ~ pages 24-25

MODEL	WATTS	RPM	AIRFLOW PERFORMANCE (CFM)					
			0" SP	0.2" SP	0.5" SP	0.75" SP	1.0" SP	1.5" SP
AXP100	106	3088	162	150	134	120	104	67
AXP125	114	2960	235	214	178	151	123	72
AXP150	113	2907	317	289	247	212	178	68
AXP200	142	2650	583	544	462	390	320	196
AXP250	293	2604	735	675	588	507	432	307
AXP300	271	2741	837	772	659	564	474	307

FOR PRE-WIRED WITH 120V POWER CORD, ADD -C TO MODEL.

MODEL	DIMENSIONS IN INCHES*								SHIP WT (lbs)
	DUCT DIA.	ØD	Ød	A	B	C	E	F	
AXP100	4"	9.8	3.9	10.6	9.1	1.2	1.2	1.1	7.0
AXP125	5"	9.8	4.9	10.6	8.7	1.2	1.2	1.1	7.0
AXP150	6"	11.8	5.9	12.2	11.3	1.2	1.2	1.2	8.0
AXP200	8"	13.4	7.9	13.9	10.9	1.6	1.2	1.2	9.0
AXP250	10"	13.4	9.8	13.9	10.4	1.6	1.2	1.2	12.0
AXP300**	12"	15.8	12.3	16.3	16.3	1.6	1.6	2.2	14.0

*DO NOT USE FOR CONSTRUCTION

CONSULT FACTORY FOR CERTIFIED PRINTS

**INCLUDES 2 DUCT REDUCERS TO FIT 12" DUCT

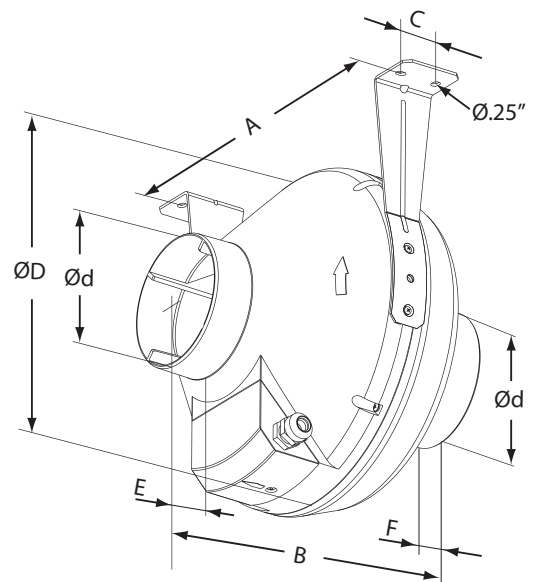

DUCT FANS

MBI CENTRIFUGAL IN-LINE FANS



MBI Centrifugal In-Line Fans are designed for residential and light commercial ventilation applications. Multiple source ducting options offer the perfect solution for whole house ventilation in multi-unit housing complexes.

Features & Benefits

- Steel housing with corrosion resistant finish
- 120V operation, other voltages available
- Removable fan cover for easy maintenance
- Easy to install - mounting brackets included
- Multiple source ducting options
- Fans may be used to supply or exhaust air
- Suitable for air temperatures from -13 F to 140 F
- Energy efficient - speed controllable (optional solid state speed control)
- Exceptionally quiet and efficient BC centrifugal motorized impeller
- Single-phase asynchronous external rotor motor
- Permanently lubricated ball bearing motor for maintenance-free operation
- Automatic reset thermal overload protection
- Fan and motor are precision balanced for quiet, vibration-free operation
- Easily accessible, external junction box with pre-wired capacitor
- Available to fit duct sizes 4", 5" & 6"; airflow capacities to 290 cfm

Accessories & Controls ~ pages 24-25

MODEL	WATTS	RPM	AIRFLOW PERFORMANCE (CFM)									
			0" SP	0.125" SP	0.20" SP	0.25" SP	0.50" SP	0.75" SP	1.0" SP	1.25" SP	1.5" SP	1.75" SP
MBI100	105	3090	147	143	139	137	123	110	99	90	76	56
MBI125	113	2920	173	169	165	162	147	126	106	85	58	30
MBI150	110	2020	221	214	206	200	171	145	120	92	65	36
MBI125/100	117	2920	232	225	219	216	197	173	148	125	99	73
MBI150/125	110	2155	290	273	262	252	211	178	146	114	84	57

IN-LINE BOOSTER FAN							
DIMENSIONS IN INCHES*							
MODEL	DUCT DIA.	A	B	C	ØD	ØD1	SHIP WT (lbs)
MBI100	4"	14.3	9.9	4.8	3.9	3.9	12.0
MBI125	5"	16.6	9.9	5.7	4.9	4.9	12.0
MBI150	6"	19.7	11.8	7.1	5.9	5.9	16.0

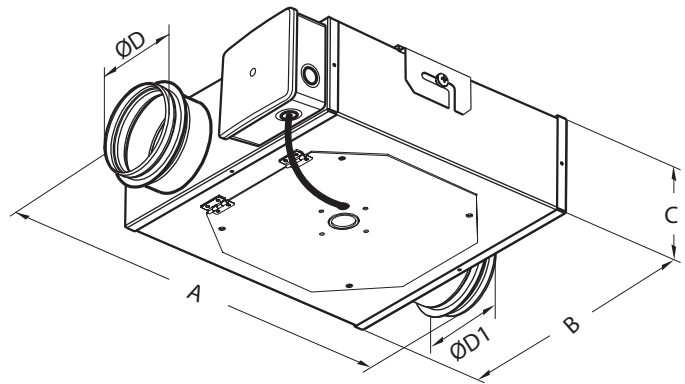

TWIN INTAKE FAN							
DIMENSIONS IN INCHES*							
MODEL	DUCT DIA.	E	F	G	ØH	ØH1	SHIP WT (lbs)
MBI125/100	5" / 4"	16.6	9.9	5.7	4.9	3.9	12.0
MBI150/125	6" / 5"	19.7	11.8	7.1	5.9	4.9	16.0

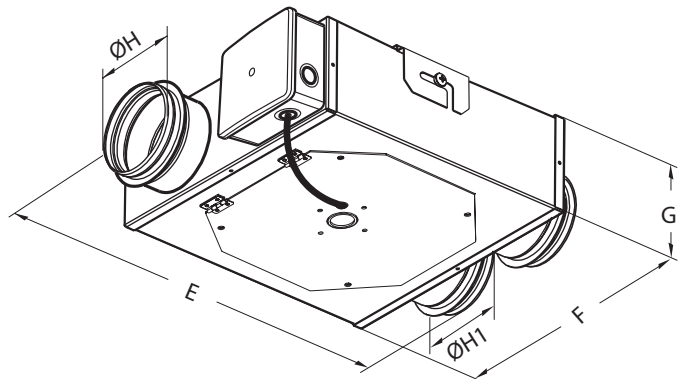

*DO NOT USE FOR CONSTRUCTION CONSULT FACTORY FOR CERTIFIED PRINTS



EXM EXTERNAL MOUNT DUCT FANS



EXM External Mount Duct Fans offer the perfect solution when limited space prevents the use of an in-line duct fan. Access and maintenance are simplified with the through-the-wall design of an EXM fan that mounts on an exterior wall.

Features & Benefits

- Steel housing with polymer coating
- Removable fan cover for easy maintenance
- Sidewall mounted on the exterior of a building
- Quiet and efficient BC centrifugal motorized impeller
- External rotor motor design results in superior motor durability
- Suitable for air streams up to 113 F
- 120V, 60 Hz, single phase operation
- Permanently lubricated ball bearing motor for maintenance-free operation
- Automatic reset thermal overload protection
- IP X4 protection
- Fits 4", 5", 6" & 8" duct
- Airflow capacity to 306 cfm
- Two-year warranty

Accessories & Controls ~ pages 24-25

MODEL	WATTS*	RPM*	AIRFLOW PERFORMANCE (CFM)				
			0" SP	0.25" SP	0.5" SP	1.0" SP	1.5" SP
EXM100	108	3100	238	223	204	134	30
EXM125	108	2950	248	231	213	146	25
EXM150	109	2250	302	286	256	159	27
EXM200	106	2300	306	291	258	148	9

*RPM AND WATTS ARE INDICATED AT 0.2" SP

MODEL	DIMENSIONS IN INCHES*					SHIP WT (lbs)
	DUCT DIA.	ØD	A	B	C	
EXM100	4"	3.9	14.0	10.3	5.4	9.0
EXM125	5"	4.9	14.0	10.3	5.4	9.0
EXM150	6"	5.9	15.8	11.8	5.4	9.9
EXM200	8"	7.9	15.8	11.8	5.4	9.9

*DO NOT USE FOR CONSTRUCTION

CONSULT FACTORY FOR CERTIFIED PRINTS

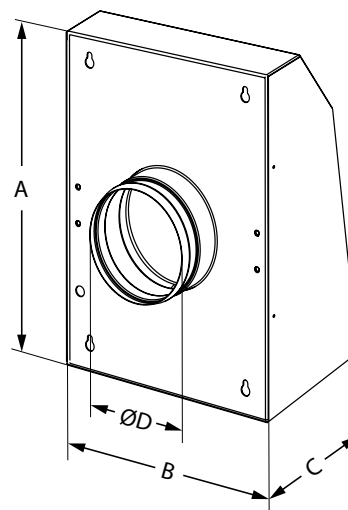

RESIDENTIAL & COMMERCIAL VENTILATION APPLICATIONS:

- Bathroom exhaust
- Kitchen ventilation
- Crawl space ventilation
- Whole house ventilation
- Garages
- Office
- Warehouse
- Restaurant

RADON FANS

ARI-C RADON FANS



ARI-C Radon Fans are specifically designed to mitigate radon gas in homes. Radon gas is a naturally occurring, radioactive gas that is emitted from the ground due to the decay of uranium in the soil. By installing an ARI fan in a home, this hazardous gas can be safely exhausted.

Features & Benefits

- Quiet, powerful, radon mitigation fan
- Factory sealed, water tight housing and junction box
- UV and corrosion resistant, durable plastic housing
- Easy to install - mounting brackets included
- May be mounted in any interior space like a basement, attic or crawl space
- Ideal for long duct runs
- Suitable for air temperatures up to 122 F
- Pre-wired with 120V power cord
- Exceptionally quiet and efficient BC centrifugal motorized impeller
- External rotor motor design results in superior motor cooling and durability
- Permanently lubricated ball bearing motor for maintenance-free operation
- Automatic reset thermal overload protection
- Fan and motor are precision balanced for quiet, vibration-free operation
- Easily accessible, external junction box
- Available to fit duct sizes 4" - 8"
- Airflow capacities to 583 cfm

Accessories & Controls ~ pages 24-25

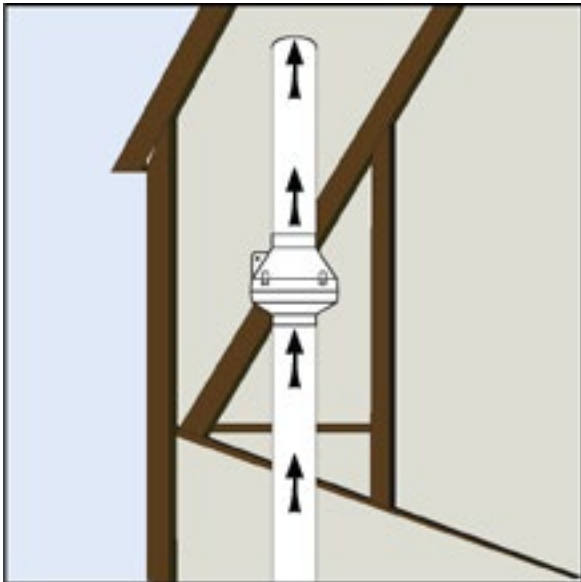

Interior Installation

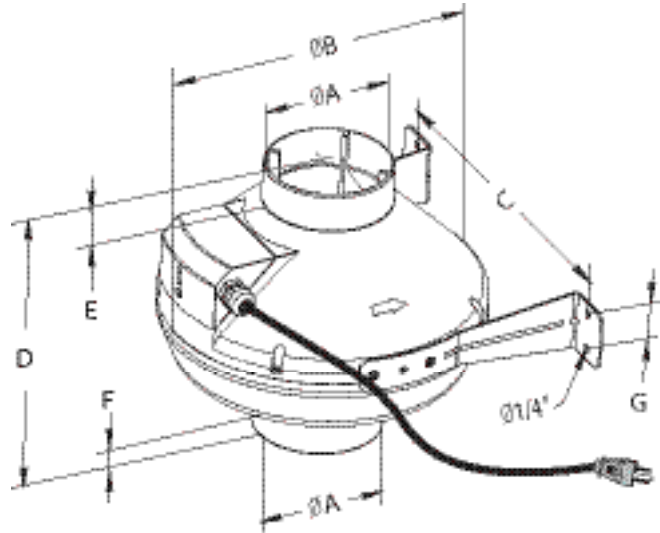

MODEL	WATTS	RPM	AIRFLOW PERFORMANCE (CFM)					SHIP WT (lbs)
			0" SP	0.2" SP	0.5" SP	0.75" SP	1.0" SP	
ARI100-C	106	3088	162	150	134	120	104	67
ARI125-C	114	2960	235	214	178	151	123	72
ARI150-C	113	2907	317	289	247	212	178	68
ARI200-C	142	2650	583	544	462	390	320	196

MODEL	DUCT DIA.	DIMENSIONS IN INCHES*							SHIP WT (lbs)
		ØB	ØA	C	D	G	E	F	
ARI100-C	4"	9.8	3.9	10.6	9.1	1.2	1.2	1.1	7.0
ARI125-C	5"	9.8	4.9	10.6	8.7	1.2	1.2	1.1	7.0
ARI150-C	6"	11.8	5.9	12.2	11.3	1.2	1.2	1.2	8.0
ARI200-C	8"	13.4	7.9	13.9	10.9	1.6	1.2	1.2	9.0

*DO NOT USE FOR CONSTRUCTION
CONSULT FACTORY FOR CERTIFIED PRINTS



DVK DRYER BOOSTER FAN



The DVK Dryer Booster Fan is designed to enhance the drying efficiency of a dryer. It is capable of overcoming a long duct run, and the in-line design simplifies installation. Unique features result in a quiet and powerful dryer boosting solution.

Features & Benefits

- Boost dryer exhaust efficiency, reduce drying times, and deliver cost savings
- External rotor motor design for quiet and efficient operation
- Backward-curved centrifugal impeller to overcome long duct runs
- In-line construction to reduce lint build-up
- Heavy gauge, drawn steel housing with baked epoxy finish
- High temperature construction: 60 C/140 F
- Thermal overload protection
- Automatic reset

Installation Tips

- DVK100B fans should be mounted at least 15 linear feet from dryer.
- Each 90-degree elbow is equivalent to 5 linear feet of duct.
- DVK100B fans are designed to vent up to 110 feet of 4-inch rigid duct.

Accessories & Controls ~ pages 24-25

MODEL	WATTS	RPM	AIRFLOW PERFORMANCE (CFM)								
			0" SP	0.2" SP	0.4" SP	0.6" SP	0.8" SP	1.0" SP	1.2" SP	1.5" SP	
DVK100B	83.4	2620	150	140	127	112	94	74	53	23	

MODEL	DIMENSIONS IN INCHES*				SHIP WT (lbs)
	ØD	Ød	A	B	
DVK100B	9.5	3.9	1.0	8.3	8.0

*DO NOT USE FOR CONSTRUCTION CONSULT FACTORY FOR CERTIFIED PRINTS

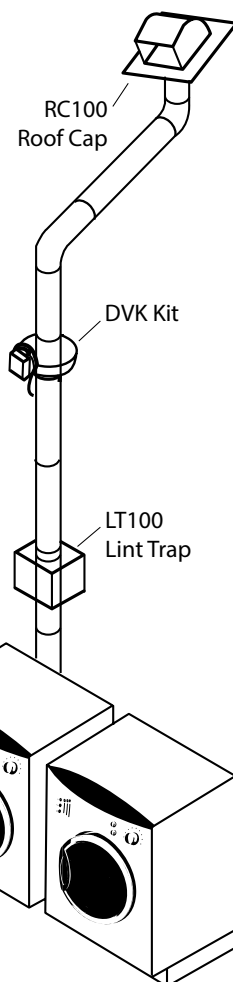
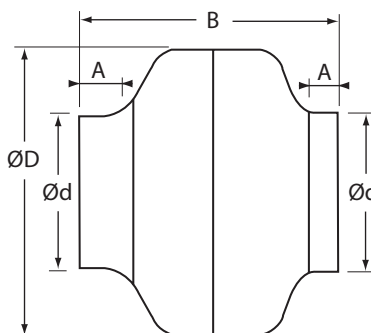

BOOSTER FAN ACTIVATION METHODS



Current Sensor (DVK100B-C Kit)

This is the preferred method for activating a dryer booster fan. When a clothes dryer is operating and drawing at least one amp of current, the current sensor automatically activates the DVK100B dryer booster fan.



Pressure Switch (DVK100B-P Kit)

The pressure switch is designed to be mounted in the duct between the fan and the dryer. When it senses dryer airflow, the switch activates the DVK100B dryer booster fan.



Pressure Switch - Mounted (DVK100B-PM Kit)

The pre-mounted pressure switch simplifies installation. Utilizing the components found in the DVK100B-P kit, the pressure switch is pre-wired and factory mounted to the DVK100B dryer booster fan.

Each of the above booster fan activation methods may be purchased as a separate accessory item. Note: Continental Fan does not recommend wiring a dryer booster fan directly into a clothes dryer.

Helpful Hints

A LT100 Lint Trap may be installed between the dryer and the booster fan to reduce lint build-up and maintenance on the fan.

AXC BATHROOM VENTILATION KITS



AXC In-Line Duct Fans provide exhaust that is two to four times greater than traditional bathroom fans. The remote mounted design is suitable for direct shower ventilation and for use with multiple ventilation points.

Features & Benefits

- Quiet, powerful, compact ventilation
- Exhaust is two to four times greater than traditional bathroom fans
- Remote mount in-line duct fan design
- Suitable for direct shower ventilation
- Designed to handle long duct runs
- Easy-to-install fan kits:
 - Adjustable grille bathroom ventilation kits
 - AeroGrille bathroom ventilation kits

Helpful Tips

- AXC fan mounts easily to attic joists.
- Always use insulated duct in unheated spaces.
- When direct venting a shower, or if noise is a significant factor, use insulated flexible duct to reduce condensation and/or noise levels.
- Add a DFC digital fan control for smart control technology and energy savings.

Accessories & Controls ~ pages 24-25

ROOM SIZE	FAN MODEL	AVAILABLE KITS
Up to 100 sq. ft.	AXC100A-ES	RG100-ES; AGK100-ES
Up to 150 sq. ft.	AXC150A-ES	RG150A-ES; AGK150A-ES; DX150A-ES; DXAGK150A-ES
Over 150 sq. ft.	AXC200A-ES	DX200A-ES

NOTE: DX KITS FEATURE TWO VENTS.

Adjustable Grille Bathroom Ventilation Kits

Attack moisture at its source. Vary airflow to suit your needs.

RG Kits Include:

AXC Fan, Mounting Brackets, GR Adjustable Grille/Collar (1), Gear Clamp (3)

- RG100-ES: 4" Fan, 147 cfm
- RG150A-ES: 6" Fan, 235 cfm



DX Kits Include:

AXC Fan, Mounting Brackets, GR Adjustable Grilles/Collar (2), Gear Clamp (7), Y-Fitting (1)

- DX150A-ES: 6" Fan, 235 cfm
- DX200A-ES: 8" Fan, 368 cfm



AeroGrille Bathroom Ventilation Kits

The attractive, non-adjustable AeroGrille provides superior ventilation when combined with an AXC in-line duct fan.

AGK Kits Include:

AXC Fan, Mounting Brackets, AeroGrille/Collar/Damper (1), Gear Clamp (3)

- AGK100-ES: 4" Fan, 147 cfm
- AGK150A-ES: 6" Fan, 235 cfm



DXAGK Kit Includes:

AXC Fan, Mounting Brackets, AeroGrille/Collar/Damper (2), Gear Clamp (7), Y-Fitting (1)

- DXAGK150A-ES: 6" Fan, 235 cfm



TF100-EC TRANQUIL BATHROOM FAN



With its high efficiency EC motor, the TF100-EC Tranquil Bathroom Fan offers whisper-quiet exhaust with sones ranging from 0.3 to 1.0. Toggle-switch positioning determines the maximum desired airflow rate, ranging from 50 to 100 cfm.

Features & Benefits

- Totally enclosed brushless electronically commutated (EC) motor
- Efficient operation at two configurable airflow levels
- Whisper-quiet sones as low as 0.3
- Low profile grille with plug & play motion sensor
- Built-in humidity sensor and time delay
- Toggle-switch selection for maximum desired airflow
- Maximum airflow ranging from 50 to 100 cfm
- Continuous low airflow operation, adjustable from 30 cfm to maximum or OFF
- Corrosion resistant 26 GA galvanized steel housing
- Removable blower assembly
- Non-metallic collar with built-in backdraft damper
- Permanently lubricated motor for continuous operation
- Automatic reset thermal overload protection
- Fits 4" duct
- ETL listed for use over a tub/shower enclosure with GFCI circuit
- HVI and ENERGY STAR® certified

Accessories & Controls ~ pages 24-25

The versatile TF100-EC fan can be configured to operate continuously at a low airflow rate to improve indoor air quality (IAQ), and it will boost automatically to a maximum desired airflow when environmental conditions change.



TF100-EC fan has been designated as one of the Most Efficient ENERGY STAR certified products in 2025.

Products that are recognized as the Most Efficient of ENERGY STAR in 2025 prevent greenhouse gas emissions by meeting rigorous energy efficiency performance levels set by the U.S. Environmental Protection Agency.

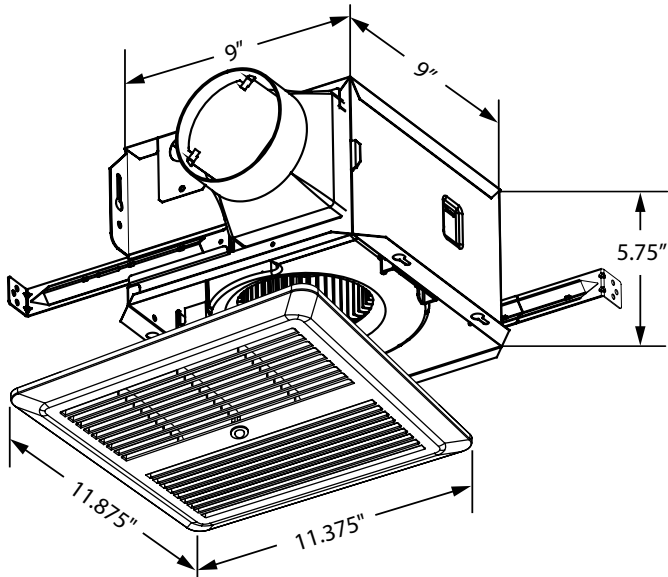

MODEL	SPEED	PERFORMANCE				POWER SUPPLY
		CFM 0.1" SP	CFM 0.25" SP	SONES	WATTS	
TF100-EC	Low	50	46	0.3	3.4	120V
	Medium	80	77	0.5	6.1	60 Hz
	High	100	95	1.0	9.7	1 Phase

*SONES AND WATTS ARE RATED AT 0.1" SP

DIMENSIONS IN INCHES*					
DUCT DIA.	GRILLE SIZE	HOUSING SIZE			SHIP WT (lbs)
		L	W	H	
4"	11.875 x 11.375	9	9	5.75	5.0

*DO NOT USE FOR CONSTRUCTION CONSULT FACTORY FOR CERTIFIED PRINTS



TF140-EC TRANQUIL BATHROOM FAN



TF140-EC Tranquil Bathroom Fan features an electronically commutated (EC) motor that provides superior ventilation and efficient performance. Toggle-switch positioning determines the maximum desired airflow rate, ranging from 80 to 140 cfm.

Features & Benefits

- Totally enclosed brushless electronically commutated (EC) motor
- Efficient operation at two configurable airflow levels
- Whisper-quiet sones as low as 0.3
- Low profile grille with plug & play motion sensor
- Built-in humidity sensor and time delay
- Toggle-switch selection for maximum desired airflow
- Maximum airflow from 80 to 140 cfm
- Continuous low airflow operation, adjustable from 30 cfm to maximum or OFF
- Corrosion resistant 26 GA galvanized steel housing
- Double hanger mounting brackets adjust up to 24" span
- Non-metallic collar with built-in backdraft damper
- Permanently lubricated motor for continuous operation
- Automatic reset thermal overload protection
- Fits 6" duct
- ETL listed for use over a tub/shower enclosure with GFCI circuit
- HVI and ENERGY STAR® certified

Accessories & Controls ~ pages 24-25

The versatile TF140-EC fan can be configured to operate continuously at a low airflow rate to improve indoor air quality (IAQ), and it will boost automatically to a maximum desired airflow when environmental conditions change.

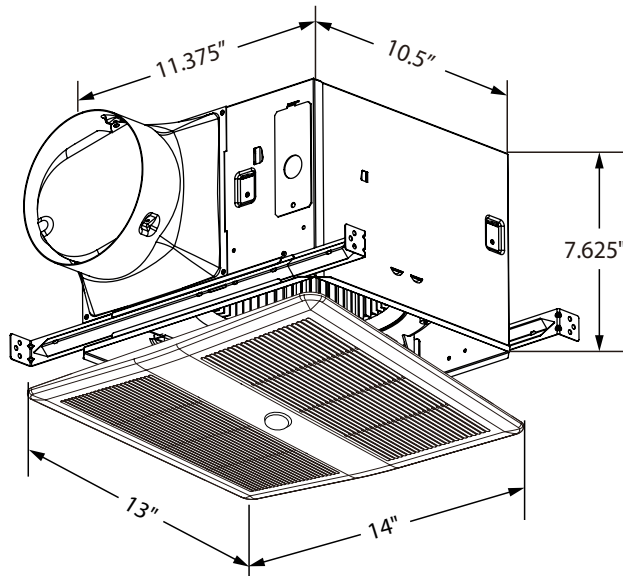

MODEL	PERFORMANCE					POWER SUPPLY
	SPEED	CFM 0.1" SP	CFM 0.25" SP	SONES*	WATTS*	
TF140-EC	Low	80	80	0.3	5.6	120V
	Medium	110	109	0.3	8.5	60 Hz
	High	140	137	0.4	13.0	1 Phase

DIMENSIONS IN INCHES*					
DUCT DIA.	GRILLE SIZE	HOUSING SIZE			SHIP WT (lbs)
		L	W	H	
6"	13 x 14	11.375	10.5	7.625	5.0

*SONES AND WATTS ARE RATED AT 0.1" SP

*DO NOT USE FOR CONSTRUCTION
CONSULT FACTORY FOR CERTIFIED PRINTS



TF140-DC TRANQUIL BATHROOM FAN



With its high efficiency DC motor, the TF140-DC Tranquil Bathroom Fan offers whisper-quiet exhaust that is under 1 sone, with multi-speed capability. Toggle-switch positioning determines the maximum desired airflow rate, ranging from 90 to 140 cfm.

Features & Benefits

- Efficient DC motor
- Multi-speed fan
- Whisper-quiet, under 1 sone
- Continuous operation with boost function
- Toggle-switch positioning for maximum desired airflow
- Airflow ranging from 90 to 140 cfm
- Superior ventilation and efficient performance
- Clean, simple grille design
- Galvanized steel housing with mounting frame
- Easy installation to joist
- Built-in backdraft damper
- 120V, 60 Hz, single phase operation
- Automatic reset thermal overload protection
- Fits 6" duct

Accessories & Controls ~ pages 24-25

The versatile TF140-DC fan can be installed as a traditional bathroom fan. Alternatively, it can be configured to operate continuously at a low airflow rate to improve indoor air quality (IAQ), and to boost the exhaust to maximum airflow with a flip of a switch.

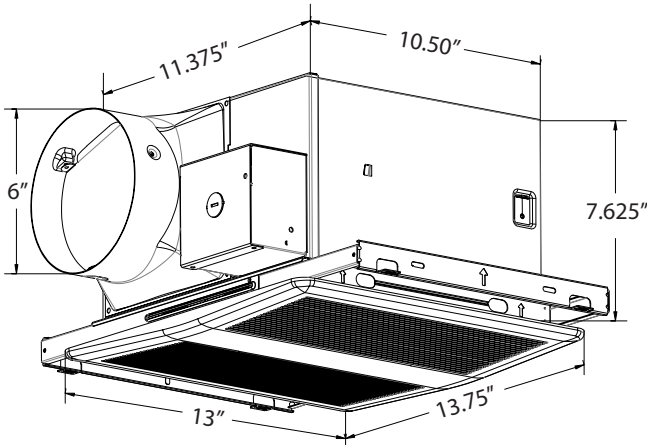

MODEL	PERFORMANCE			POWER SUPPLY
	CFM 0.1" SP	SONES	WATTS	
TF140-DC	90	0.5	8.1	120V 60 Hz 1 Phase
	110	0.9	10.3	
	120	1.2	12.2	
	140	1.5	15.6	

DIMENSIONS IN INCHES*					
DUCT DIA.	GRILLE SIZE	HOUSING SIZE			SHIP WT (lbs)
		L	W	H	
6"	13 x 13.75	11.375	10.5	7.625	5.0

*DO NOT USE FOR CONSTRUCTION

CONSULT FACTORY FOR CERTIFIED PRINTS



TF TRANQUIL BATHROOM FANS



TF Tranquil Bathroom Fans are available in lighted, non-lighted and low-profile versions, providing superior ventilation and efficient performance suitable for all interiors. The built-in damper prevents a backdraft when the fan is not operating.

Features & Benefits

- Whisper-quiet, 2.0 sones or less
- Available styles:
 - Lighted (TF80L & TF110L)
 - Non-lighted (TF80, TF110, TF150, TF200 & TF300)
 - Low-profile, 3-3/8" depth housing (TF80N & TF100N)
- May be mounted in a wall (low-profile models only) or ceiling
- Double hanger mounting brackets adjust up to 24" span
- Durable polymeric resin grille for long life
- 26 GA galvanized steel housing
- Built-in backdraft damper
- Efficient AC motor
- 120V, 60 Hz operation
- Automatic reset thermal overload protection
- Max 26W GU24 fluorescent light
- ETL listed for use over a tub/shower enclosure with GFCI circuit

Accessories & Controls ~ pages 24-25

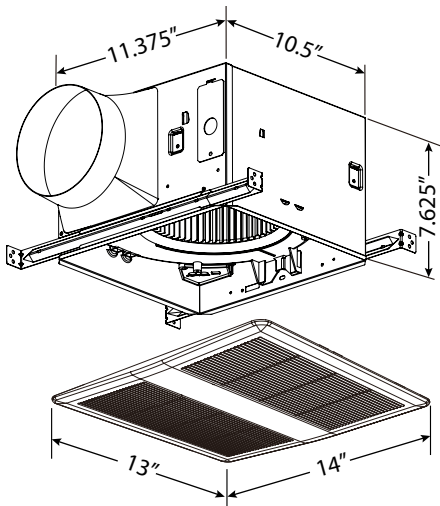

(Non-Lighted)

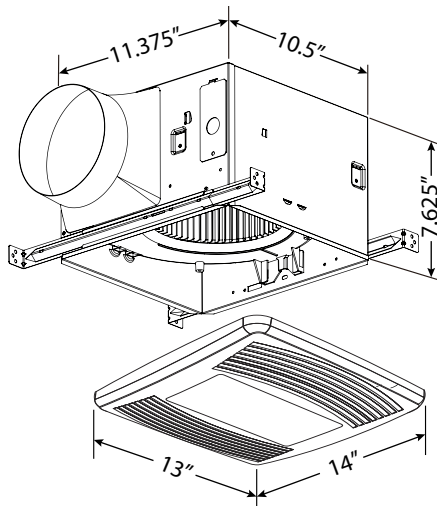

(Lighted)

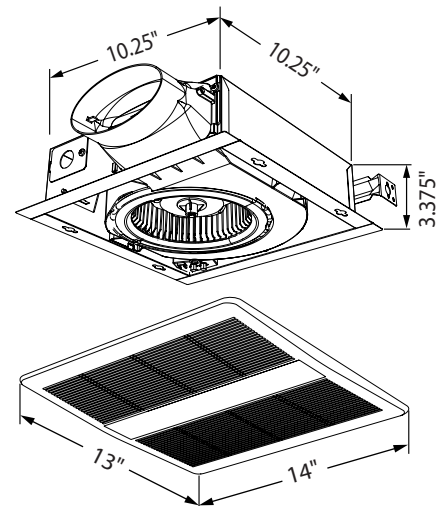

(Low Profile)

		PERFORMANCE							
FAN STYLE	MODEL	CFM 0.1" SP	CFM 0.25" SP	SONES*	WATTS	DUCT DIA.	SHIP WT (lbs)	ENERGY STAR® & HVI CERTIFIED	APPLICATION
LIGHTED	TF80L	80	58	0.4	22.8	4" & 6"	5.0	No	Residential
	TF110L	110	100	0.9	28.0	4" & 6"	5.0	No	Residential
NON-LIGHTED	TF80	80	58	0.4	22.8	4" & 6"	5.0	No	Residential
	TF110	110	100	0.9	28.0	4" & 6"	5.0	No	Residential
	TF150	150	130	0.9	35.0	6"	5.0	No	Residential / Commercial
	TF200	200	188	2.0	24.0	6"	5.0	No	Commercial
	TF300	290	268	4.0	52.0	6"	5.0	No	Commercial
LOW-PROFILE	TF80N	80	62	1.2	25.9	4" Oval	5.0	Yes	Residential
	TF100N	100	86	2.0	24.6	4" Oval	5.0	Yes	Residential

*SONES ARE RATED AT 0.1" SP

DO NOT USE FOR CONSTRUCTION
CONSULT FACTORY FOR CERTIFIED PRINTS



ENERGY STAR® & HVI Certified only models TF80N & TF100N

TF400 TRANQUIL BATHROOM FAN



TF400 Tranquil Bathroom Fan offers higher air delivery for commercial applications. The efficient DC motor is designed for continuous and quiet operation.

Features & Benefits

- Totally enclosed brushless DC motor
- Ceiling mount design for commercial applications
- Superior ventilation and efficient performance
- Rugged 26 GA galvanized steel housing w/corrosion resistant finish
- Durable polymeric resin grille for long life
- Easy installation
- 4-point mounting capability
- Built-in backdraft damper
- 120V, 60 Hz operation
- Permanently lubricated motor for continuous operation
- Automatic reset thermal overload protection
- ETL listed for use over a tub/shower enclosure with GFCI circuit
- Fits 8" duct

Accessories & Controls ~ pages 24-25

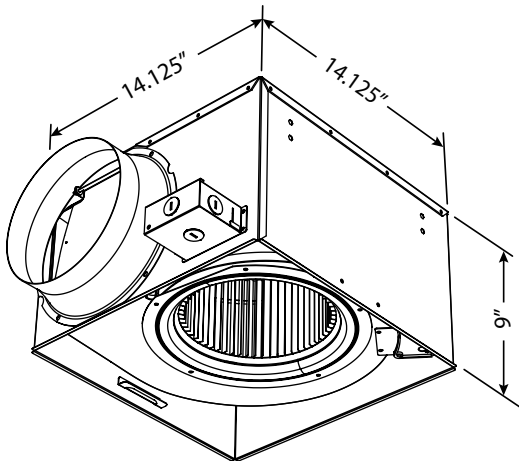
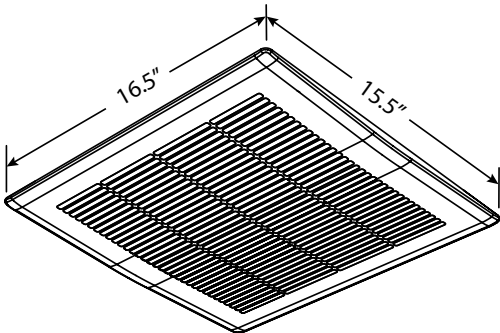

MODEL	PERFORMANCE			
	CFM 0.1" SP	CFM 0.25" SP	SONES	WATTS
TF400	400	390	3.0	40.0

DIMENSIONS IN INCHES*					
DUCT DIA.	GRILLE SIZE	HOUSING SIZE			SHIP WT (lbs)
		L	W	H	
8"	15.5 x 16.5	14.125	14.125	9.0	14

*DO NOT USE FOR CONSTRUCTION

CONSULT FACTORY FOR CERTIFIED PRINTS



BATHROOM FANS & KITS

CEF CEILING EXHAUST FANS



CEF Ceiling Exhaust Fans provide the perfect solution for hotels, public restrooms, or any commercial spaces that require continuous ventilation. These ceiling or in-line mount, exhaust fans feature a low profile grille and an integral backdraft damper.

Features & Benefits

- Acoustically insulated galvanized steel housing
- Low profile grille
- Integral backdraft damper
- Easily removable blower assembly
- Horizontal (standard) or vertical discharge
- 8 position mounting brackets
- Anti-vibration mounts isolate motor for smooth operation
- Thermally protected fan motor

Accessories / Options

- Variable speed control
- Radiation damper
- Time delay switch
- Roof and wall caps
- In-line kit
- Square to round discharge transition (CEF400 & larger)

Models CEF100 Thru CEF300

MODEL	WATTS	RPM*	CFM 0.125 SP	DUCT DIA.	WT (lbs)
CEF100	88	640/650	109	6"	23
CEF150	96	710/750	157	6"	23
CEF200	124	740/760	210	8"	23
CEF250	160	830/860	259	8"	23
CEF300	204	935/950	308	8"	24

*RPM SHOWN IS HORIZONTAL / VERTICAL DISCHARGE AT 0.125".

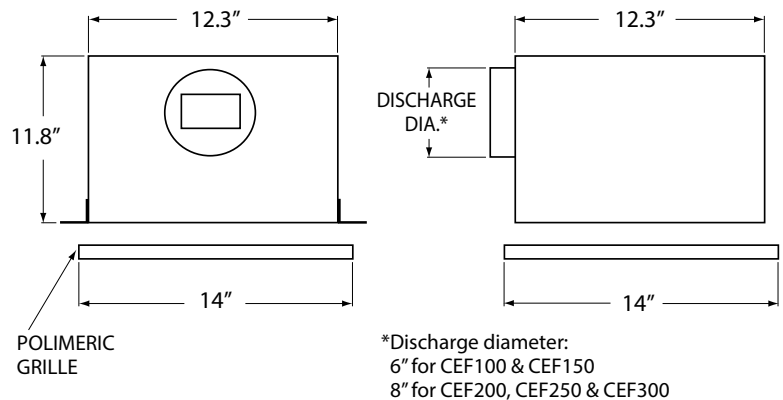

Models CEF400 & CEF700

MODEL	WATTS	RPM*	CFM 0.125 SP	DUCT DIA.	WT (lbs)
CEF400	137	735/755	434	18.5" x 4.5"	34
CEF700	298	960/985	701	18.5" x 4.5"	34

*RPM SHOWN IS HORIZONTAL / VERTICAL DISCHARGE AT 0.125".

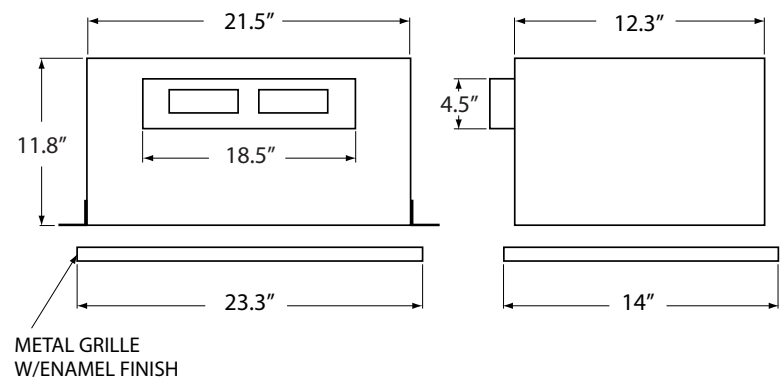

VISIT CONTINENTALFAN.COM FOR COMPLETE PERFORMANCE DATA

DO NOT USE FOR CONSTRUCTION
CONSULT FACTORY FOR CERTIFIED PRINTS

CX1000 PORTABLE AIR PURIFIER



Using patented technology, CX1000 Portable Air Purifier removes airborne particles, neutralize odors and chemicals, and render germs, viruses and bacteria harmless. Ideal applications include homes, schools, day cares, offices, beauty salons, and more.

Features & Benefits

- 1,000 square feet of complete air purification
- Create a cleaner environment and promote health and wellness
- High-intensity, UVC germicidal lamp
- Photocatalytic Oxidation (PCO) process neutralizes odors and toxic VOCs
- Easy maintenance
- Built-in electronic service lights
- Electronic sensors constantly monitor air quality
- Warning lights signal presence of toxic chemicals and fumes
- Ozone free
- Limited 2-year warranty (excludes lamp and filters)

Five-stage process to purify indoor air:

1. Treated pre-filter - removes particles to 5 microns
2. Activated carbon filters (2) - reduce toxic chemicals and gases
3. Hospital grade HEPA filter - purges allergens to 0.3 microns
4. Reactive catalyst - neutralizes VOCs, toxic chemicals, and odors
5. UVC light - renders germs, viruses, and bacteria harmless

MODEL	DIM. (in.)	MAX AIRFLOW (cfm)	VOLTAGE (V)	POWER (watts)	LAMP (watts)	UV RANGE (nm)	LAMP INTENSITY ($\mu\text{W}/\text{cm}^2$ @Surface)	WT (lbs)
CX1000	21.5 x 18 x 8	200	1/120/60	100	8	254	7,434	23
	APPLICATION (sq. ft.)		SERVICE INTERVALS*		WARRANTY		CATALYST	
	1,000 (auto mode)		UVC lamp 1 year; filters 2 years		2 year (excluding lamp and filters)		Metal Oxides	

*SERVICE INTERVALS ARE SUBJECTIVE TIMES AND MAY FLUCTUATE BASED ON ENVIRONMENT.

CX1000 Construction

1. Air inlet grille with safety lock
2. 5.0 micron pre-filter
3. 1st stage gas adsorption layer (activated carbon)
4. 2nd stage gas adsorption layer (activated carbon)
5. 0.3 micron hospital grade HEPA filter
6. High impact ABS plastic
7. Photo-catalytic converter
8. High output germicidal UVC lamp
9. Air outlet grille with safety lock

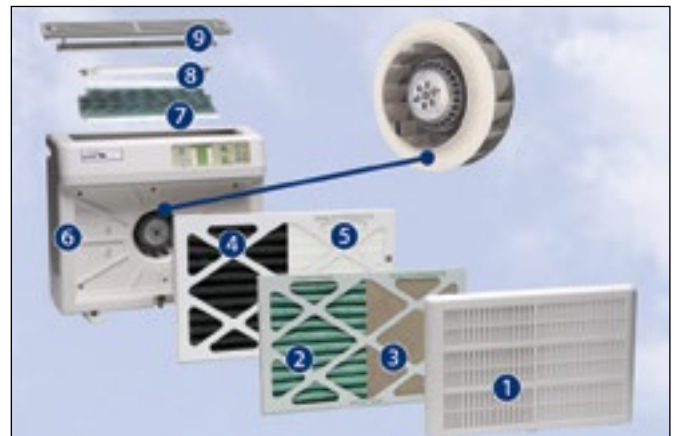

CX Air Purifiers:

- Create a cleaner environment
- Ease breathing problems
- Alleviate fatigue and headaches
- Promote health and wellness



- Cut dust and cleaning requirements
- Reduce asthma, hay fever and sinus problems
- Control pet odors and dander
- Relieve sore throats, runny noses and sneezing

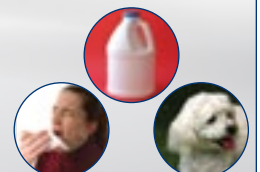

CX-PRO IN-DUCT AIR PURIFIER



CX-Pro combines three powerful purification forces in an in-duct whole house air purifier. The UVC germicidal lamp neutralizes viruses, bacteria and mold. The patented design uses a Photocatalytic Oxidation (PCO) process to neutralize odors and toxic VOCs into benign constituents and an activated carbon adsorption media to trap odors and toxic chemicals.

Features & Benefits

- High-intensity, UVC germicidal lamp
- Aluminum substrate and carbon media never need replacing
- Easily installs in an HVAC duct system
- Install in supply duct, in return plenum or above AC coil
- Irradiates AC coil of toxic organics and biofilm
- Neutralizes viruses, bacteria and mold
- Breaks down VOCs and biologicals
- Traps odors and toxic chemicals
- Ozone free
- Pre-wired 120V power cord; 230V option
- 2-year lamp efficiency
- Limited 10-year warranty (excludes lamp)
- In as little as two hours the CX-Pro neutralizes:
 - 93.6% of airborne germs
 - 80% of odors and VOCs

MODEL	IN-DUCT DIM. (in.)	SIZING (tons)	PRESSURE DROP (in. wg)	SURFACE AREA (sq. in.)	VOLTAGE (V)	UV RANGE (nm)	LAMP (watts)	LAMP INTENSITY ($\mu\text{W}/\text{cm}^2@1\text{m}$)	WT (lbs)
CX-Pro	17.75	1.5 - 5.0	0.02	3,500	120/230	254	50	135	3.6



1. UVC germicidal lamp
 - Neutralizes airborne microbes such as viruses, bacteria and mold
 - Irradiates AC coil of toxic organics and biofilm
2. Catalytic aluminum substrate
 - Breaks down VOCs and biologicals with its patented PCO process
3. Activated carbon adsorption media
 - Traps odors and toxic chemicals with its activated carbon surface

How does the CX-Pro work?

As indoor air circulates through the duct system, it passes through the treatment zone of the CX-Pro. The UVC germicidal lamp neutralizes an organism's DNA, preventing it from replicating. The catalytic aluminum substrate, which is permanently bonded with titanium dioxide, maximizes the exposure of biologicals and toxic gases. The PCO process occurs when the catalyst is excited by the irradiation of UVC light, deactivating microbes and deconstructing molecular bonds. While the carbon adsorption media traps odors and toxic impurities, the PCO process catalyzes impurities and refreshes the carbon adsorption media.

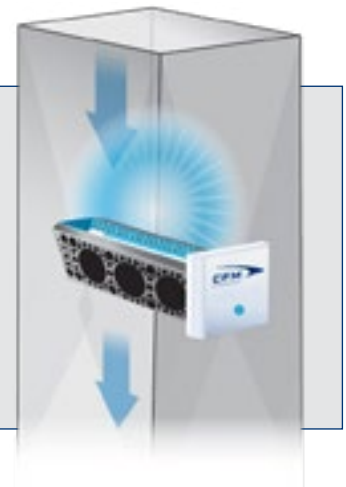

CX-AIRE IN-DUCT AIR PURIFIER



Features & Benefits

- Compact design easily installs in an HVAC duct system
- Effectively neutralizes viruses, bacteria, mold and fungi
- Irradiates AC coil of toxic organics and biofilm
- High-intensity, energy efficient UVC germicidal lamp
- Install in supply duct, return plenum or above AC coil
- Continuous operation
- Ozone free
- Pre-wired 120V power cord
- Built-in safety switch
- 2-year lamp efficiency; simple twist-and-lock replacement
- Limited 10-year warranty (excludes lamp)

With the power of UVGI (ultraviolet germicidal irradiation) light, CX-Aire In-duct Air Purifier effectively neutralizes harmful airborne viruses, bacteria, mold and fungi. The UVC light purifies the indoor air as it circulates through the treatment zone within the HVAC duct system.

MODEL	IN-DUCT DIM. (in.)	SIZING (tons)	VOLTAGE (V)	UV RANGE (nm)	LAMP (watts)	LAMP INTENSITY ($\mu\text{W}/\text{cm}^2@1\text{m}$)
CX-Aire	16	1.5 - 5.0	120	254	30	62

Where to position the CX-Aire

Indoor air in a typical HVAC system will recirculate 75-150 times a day. A CX-Aire installed in a supply or return duct will provide cumulative exposure that effectively controls airborne contaminants. The UVC light neutralizes airborne viruses, bacteria, and mold that circulate through the treatment zone in the ductwork.

An AC coil is often located in moist, dark places where mold and toxic biofilm can easily breed. During an HVAC system cycle, mold and toxic biofilm are released into the air because of an unhealthy buildup on the AC coil. When a CX-Aire is installed near the AC coil, the UVC light cleanses the coils and prevents that unhealthy buildup from reforming. This allows an AC system to run efficiently, which consequently reduces energy and maintenance costs and extends the life of the equipment.

Double the germ fighting power by locating a CX-Aire in a return or supply duct and a second CX-Aire above an AC coil.

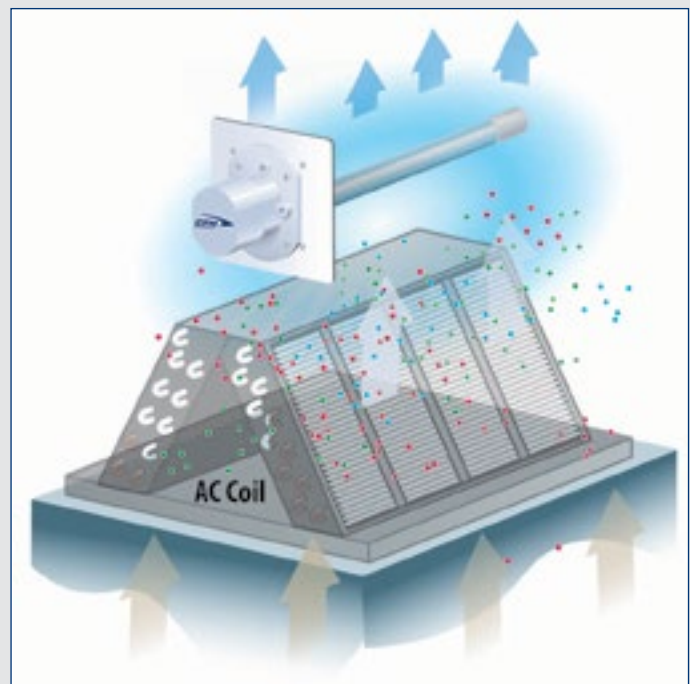

DAMPERS

BDD BACKDRAFT DAMPERS



BDD Backdraft Dampers provide an economical solution to troublesome backdrafts. These premium quality backdraft dampers feature aluminum butterfly damper blades and are available in either spring loaded or gravity operated designs.

Spring Loaded Dampers

- Neoprene damper seal to minimize air leakage
- Steel housing, aluminum butterfly damper blades
- Gasket designed to withstand temperatures from -22 F to 180 F
- Requires from 0.04 to 0.08 in. wg pressure to open
- Simple installation in any position - entire assembly inserts into duct
- Exterior foam gasket assures a tight seal against duct
- 4", 5", 6" & 8" sizes include stamped metal sleeve with center pin / post designs
- 10" & 12" sizes include rolled metal sleeve with center post design

Gravity Operated Dampers

- Low air leakage design
- Galvanized steel housing
- Aluminum butterfly damper blades
- Gravity operated closure
- Install in horizontal or vertical (upblast only) position
- Suitable for supply or exhaust applications
- Available in 7", 14" & 16" sizes

SPRING LOADED DAMPERS 4", 5", 6" & 8"

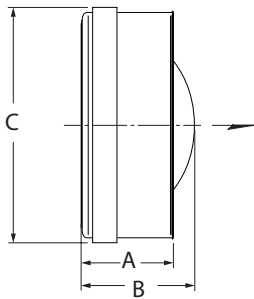

SPRING LOADED DAMPERS 10" & 12"

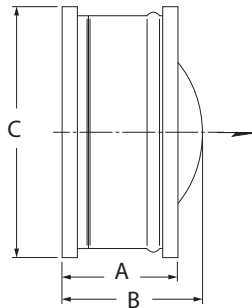

GRAVITY OPERATED DAMPERS 7", 14" & 16"

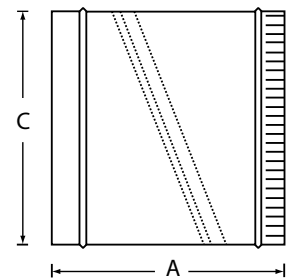

MODEL	A	B	C (NOMINAL)	GAUGE
SPRING LOADED DAMPERS				
BDD100	1.8	2.0	4	20
BDD125	2.0	2.5	5	20
BDD150	2.5	3.0	6	20
BDD200	2.8	3.8	8	20
BDD250	4.8	6.0	10	20
BDD300	6.3	6.8	12	20
GRAVITY OPERATED DAMPERS				
BDD175	7.0	-	7	28
BDD355	12.0	-	14	24
BDD400	14.0	-	16	22

*DO NOT USE FOR CONSTRUCTION
CONSULT FACTORY FOR CERTIFIED PRINTS

AIRFLOW PERFORMANCE (CFM)

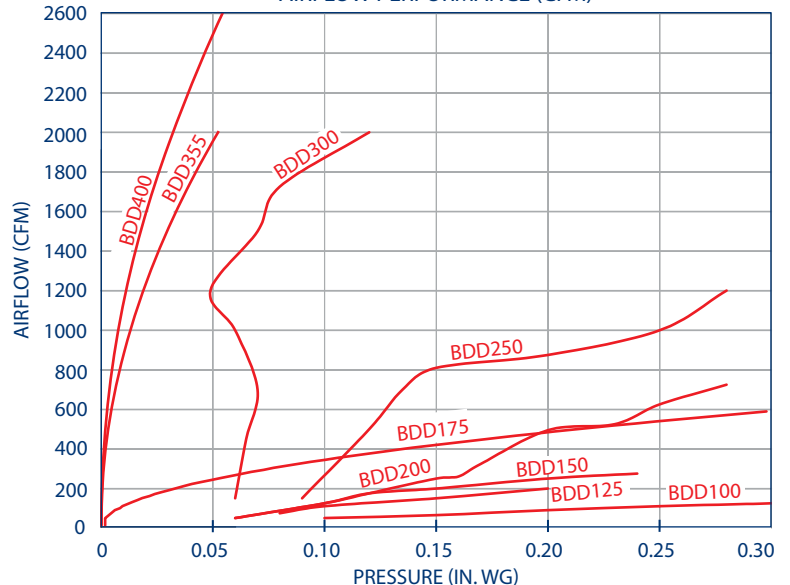

IRIS DAMPERS

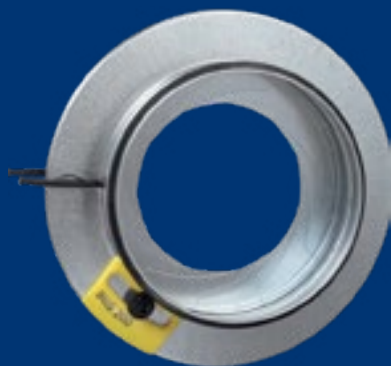

The IRIS Damper is a brilliantly simple solution for fast and exact measurement, balance and control of airflow. It is ideal for supply and exhaust tracking control, individual comfort control, and any space requiring accurate airflow regulation.

Features & Benefits

- Precise airflow measurement, reduced field labor time
- Single station measurement and control
- Accurate air balancing to +/- 5% in straight duct
- Compact design, superior performance
- Fitted EPDM gasket for airtight mounting
- Fully retractable blades for duct cleaning
- Ideal for office buildings, pharmaceuticals, clean rooms and laboratories
- Available in 4" to 32" sizes; capacities to 20,000 cfm
- Max operating temperature:
 - 180 F continuous
 - 250 F intermittent

IRIS Damper

- Hot dipped galvanized steel construction

IRIS-S Damper

- AISI 316 stainless steel construction
- Prolonged excellence in extreme conditions
- Ideal for corrosive environments

Positive Seal Construction (Optional)

Some applications may require a fully closed damper. For those requiring a 100% shutoff, a positive seal option is available on sizes 4" through 12", in both galvanized and stainless steel IRIS dampers.

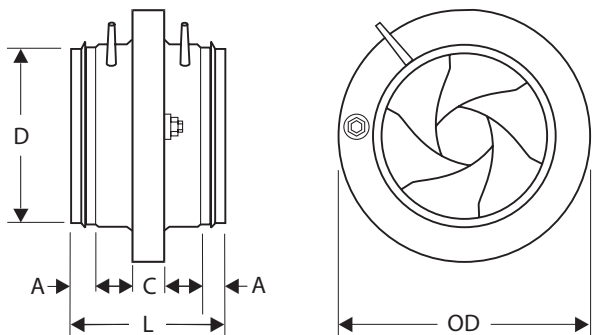

Simple Operation

Using a pressure gauge and a damper's Airflow Adjustment Chart, desired airflow in a duct can be attained by simply turning the damper adjustment nut until the required pressure drop is reached (Fig. 1).

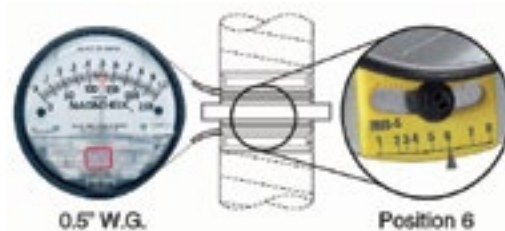

MODEL	DIMENSIONS IN INCHES*					WT (lbs)
	A	C	D	L	OD	
IRIS-04, IRIS-S-04	1.2	0.6	3.9	4.6	6.5	1.1
IRIS-05, IRIS-S-05	1.2	0.6	4.9	4.6	7.4	1.5
IRIS-06, IRIS-S-06	1.2	0.6	5.9	4.6	9.1	2.0
IRIS-08, IRIS-S-08	1.2	0.6	7.8	4.6	11.2	3.1
IRIS-10, IRIS-S-10	1.6	0.7	9.8	5.3	13.2	4.6
IRIS-12, IRIS-S-12	1.6	0.7	11.8	6.1	16.1	7.7
IRIS-16, IRIS-S-16	2.4	0.8	15.7	7.5	20.7	14.1
IRIS-20, IRIS-S-20	2.0	0.8	19.6	6.7	25.8	21.2
IRIS-25, IRIS-S-25	2.0	0.9	24.7	6.7	32.1	34.4
IRIS-32, IRIS-S-32	3.9	0.9	31.4	10.6	40.0	55.1

*DO NOT USE FOR CONSTRUCTION
CONSULT FACTORY FOR CERTIFIED PRINTS

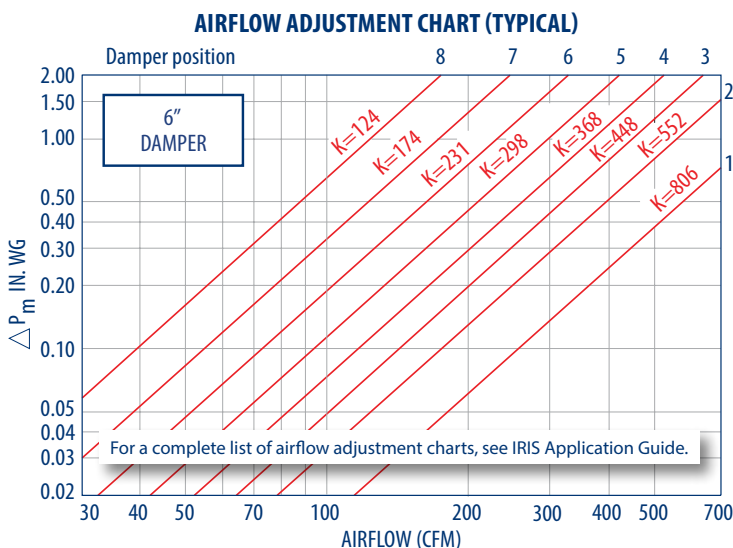

ACCESSORIES, GRILLES & CONTROLS

ACCESSORIES

Sound Attenuators

- SA100 Sound Attenuator, 4" Duct
- SA150 Sound Attenuator, 6" Duct
- SA200 Sound Attenuator, 8" Duct
- SA250 Sound Attenuator, 10" Duct
- SA300 Sound Attenuator, 12.4" Duct
- SA400 Sound Attenuator, 16" Duct



SA sound attenuators reduce fan noise traveling along ventilation ducts. Ideal for either supply or exhaust ducts.

Duct Reducers/Increasers

- DRI-04-03 Duct Reducer/Increaser, 4"-3" Duct, Plastic
- DRI-06-04 Duct Reducer/Increaser, 6"-4" Duct, Galvanized
- DRI-08-06 Duct Reducer/Increaser, 8"-6" Duct, Galvanized
- DRI-10-08 Duct Reducer/Increaser, 10"-8" Duct, Galvanized
- DRI-12-10 Duct Reducer/Increaser, 12"-10" Duct, Galvanized
- DRI-14-12 Duct Reducer/Increaser, 14"-12" Duct, Galvanized

DRI duct reducers/increasers are used to transition a duct from a larger or smaller size. Available in 28 Ga.



Wye Fittings

- WYE-04 Y-Fitting, 4"x4"x4" Duct
- WYE-06 Y-Fitting, 6"x6"x6" Duct
- WYE-08 Y-Fitting, 8"x8"x8" Duct



WYE fittings provide an airtight branch fitting. The crimp and bead edging ensures an easy connection.

Gear Clamps (for Flexible Duct)

- GC150 Gear Clamps for 4" - 6" Duct, Stainless Steel
- GC200 Gear Clamps for 5.5" - 8.5" Duct, Stainless Steel

Stainless steel gear clamps easily connect a duct fan to flexible insulated duct and other auxiliary pieces.



Flexible Insulated Duct

- FLM100 Flexible Insulated 4" Duct - 12.5'
- FLM100-25 Flexible Insulated 4" Duct - 25'
- FLM125 Flexible Insulated 5" Duct - 25'
- FLM150 Flexible Insulated 6" Duct - 25'
- FLM200 Flexible Insulated 8" Duct - 25'
- FLM250 Flexible Insulated 10" Duct - 25'
- FLM300 Flexible Insulated 12" Duct - 25'



FLM models are UL-181 and ULCS-110 M Class air duct, wrapped with 2-ply polyester laminated inner core.

Mounting Clamps (for Rigid Duct)

- MC100 Mounting Clamps for Rigid 4" Duct (2pc)
- MC125 Mounting Clamps for Rigid 5" Duct (2pc)
- MC150 Mounting Clamps for Rigid 6" Duct (2pc)
- MC200 Mounting Clamps for Rigid 8" Duct (2pc)
- MC250 Mounting Clamps for Rigid 10" Duct (2pc)
- MC300 Mounting Clamps for Rigid 12" Duct (2pc)
- MC355 Mounting Clamps for Rigid 14" Duct (2pc)



MC mounting clamps are designed for use with rigid duct. The foam neoprene layer creates an air tight installation.

Roof Caps

- RC100 Roof Cap, 4" Duct, Black Plastic
- RC150 Roof Cap, 6" Duct, Black Plastic
- RC200 Roof Cap, 8" Duct, Black Plastic



Black plastic roof caps include damper, screen, and collar.

Wall Caps

- WC100 Wall Cap, 4" Duct, Aluminum, Reducer 4" - 3"
- WC150 Wall Cap, 6" Duct, Aluminum
- WC200 Wall Cap, 8" Duct, Aluminum



Aluminum wall caps include spring controlled damper.

Guards

- PG100 Guard, 4" Duct
- PG125 Guard, 5" Duct
- PG150 Guard, 6" Duct
- PG200 Guard, 8" Duct
- PG250 Guard, 10" Duct
- PG300 Guard, 12" Duct



Utilize a PG guard as a grille, or mount it directly on the outlet/inlet of a fan to allow for a safe installation.

Louvered Shutters (w/Tail Piece)

- LS100-4W Louvered Shutter, 4" Duct
- LS150-6W Louvered Shutter, 6" Duct

LS louvered shutters are plastic molded vent hoods that prevent wind and rain from entering the vent.



Lint Trap

- LT100 Lint Trap for 4" Dryer Duct

Reduce maintenance associated with dryer vents by installing a LT100 Lint Trap, which mounts to a wall or ceiling.



GRILLES

Adjustable Ventilation Grilles

- GR100 Adjustable Grille 4", Collar
- GR150 Adjustable Grille 6", Collar
- GR200 Adjustable Grille 8", Collar
- GR100-6PK Adjustable Grille 4", Collar - 6 pcs
- GR150-6PK Adjustable Grille 6", Collar - 6 pcs



Designed for ceiling or wall applications, the fully adjustable GR ventilation grilles are easy to install and adjust.

AeroGrille Ventilation Grilles

- AG150 AeroGrille 6"
- AG150-C AeroGrille 6", Collar
- AG150-CD AeroGrille 6", Collar, Damper



AeroGrilles are designed for use with either in-line or external mount duct fans.

CONTROLS

Digital Fan Control

- DFC120V Digital Fan Control 5 Modes of Operation - 120V

DFC uses smart technology to automatically calculate the airflow required to achieve acceptable IAQ.



Occupancy Sensor

- SOS125V Occupancy Sensor - 5 amp

Single relay occupancy sensor features 180 degree field of view with coverage up to 900 sq. ft.



Variable Speed Controls (Solid State)

- VSC3 Knob-Style - 115V, 3 amp - 3 Wire
- VSC5 Knob-Style - 115V, 5 amp - 3 Wire
- VSC5-230 Knob-Style - 230V, 5 amp - 4 Wire
- VSC10 Knob-Style - 115V, 10 amp - 3 Wire
- DVSC5 Decora Slide - 115V, 5 amp



Variable speed controls are designed for AC motors. Not for use with any model of TF Bathroom Fan.

Thermostat

- TST120V Line Voltage Thermostat, 120V

TST120V thermostat is suitable for direct connection with any resistance heating element or unit heater.



Current Sensor (Solid State)

- CS120AF Current Sensor, 120V, Solid State

The current sensor detects AC current. It is ideal for ON/OFF sensing of remote equipment.



Digital Timers

- DT60 Digital Timer 10 - 20 - 30 - 60 Minutes

Time control auto shut off, in preset intervals, allows for proper ventilation and energy savings.



Pressure Switch (w/Time Delay)

- PST120V Pressure Switch w/Time Delay

PST120V is an airflow proving switch designed for HVAC or energy management applications.



Spring Wound Timer

- CT100V Spring Wound Timer 0 - 1 Hour

CT timer provides energy savings by limiting the "on-time" of the fan. Face plate not included.



Auto Transformer

- TF120V Auto Transformer - 90/60V

TF auto transformer allows for voltage to be regulated to 60V and 90V increments.



On/Off Switch (w/Pilot Light)

- PLS120V ON/OFF Switch w/Pilot Light

The neon light is ON when the switch is in the ON position. Face plate not included.



HVLS FANS

CMX HVLS FANS

Features & Benefits

- High efficiency EC brushless motor, continuous duty operation
- Robust steel structure for long life
- Virtually silent, 5-blade aluminum airfoils
- Corrosion resistant, anodized aluminum airfoil design
- Plastic, aerodynamically-shaped blade terminals
- Optimized performance and acoustic comfort
- Security wire, stabilizing cables and hub ring for safety
- 200-240Vac or 400-480Vac, 50/60 Hz, 3 phase operation
- Speed controllable
- Maintenance-free, gearless motor
- Maximum permissible ambient temperature: 120 F
- Integrated EMC (electromagnetic interference) filters
- Easily clean with low pressure water jets

Accessories

- Downrod (32" standard)
- I-beam mounting kit
- Glulam mounting kit
- Z purlin brackets
- Potentiometer speed control
- Smart touch controller

CMX HVLS Fans are designed to redistribute heated or cooled air to floor level. These high volume, low speed fans eliminate temperature layers in the ceiling space and create a more comfortable environment inside a building. When a CMX Fan is integrated with an HVAC system, the net result is energy savings and CO2 emission reduction.

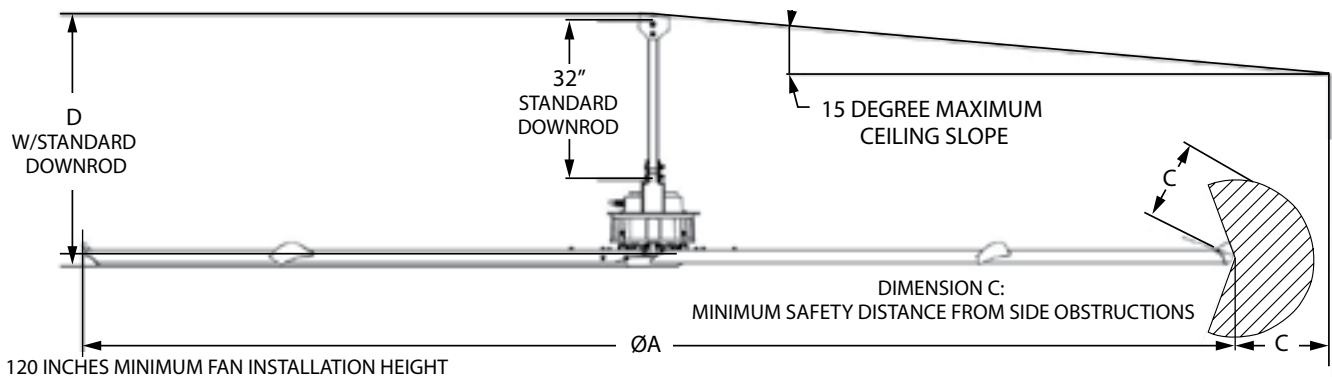

IP65 motor protection

MODEL	PERFORMANCE					
	MAX RPM	MAX SERVICED DIA. (ft)	SOUND ⁽¹⁾ Lp dBA	HP	MAX CURRENT (amps)	MINIMUM CIRCUIT SIZE
CMX-10	130	98	55	1.1	3.8	10A@200-240V, 3Φ 10A@400-480V, 3Φ
CMX-12	85	117	52	0.8	2.6	
CMX-14	80	136	55	0.9	2.7	
CMX-16	70	156	56	1.1	3.5	
CMX-18	63	176	49	1.2	3.6	
CMX-20	55	195	50	1.2	3.7	
CMX-24	51	234	55	1.6	4.8	

DIMENSIONS			
ØA (ft)	C (ft)	D (in.)	WT (lbs)
10	1.2	49	176
12	1.5	49	194
14	1.5	50	220
16	1.8	50	234
18	1.8	51	249
20	1.8	51	260
24	1.8	51	282

@240V/60Hz supply, max speed

⁽¹⁾Sound testing taken with the sensor 1.5 m above the floor and 6 m from the center of the fan at 5 m high, measured in a laboratory environment. Actual results in field conditions may vary due to sound reflecting surfaces and environmental conditions.

*DO NOT USE FOR CONSTRUCTION
CONSULT FACTORY FOR CERTIFIED PRINTS

NFPA 13 Standards for HVLS Fans

- Maximum allowable fan diameter of 24 feet.
- Fans must be approximately centered between four adjacent sprinklers.
- There must be a 3 foot minimum clearance from the sprinkler deflector to the fan.
- Fans must be interlocked to shut down immediately upon receiving a water flow signal from the fire alarm system.

DSF DESTRATIFICATION FANS



DSF Destratification Fans force heated or cooled air down to floor level, eliminate temperature layers in the ceiling space, and create a more comfortable environment inside a building. The net result is energy savings, along with maximizing the efficiency of an HVAC system.

Features & Benefits

- Reduce hot and cold spots through the mixing of air in large spaces
- Lower energy costs, increased comfort
- Ideal for any building with ceilings 15' or higher
- Breaks up stratification layers
- Powerful, axial flow fan
- External rotor motor design results in superior motor cooling and durability
- Speed controllable using optional solid state speed control
- Permanently lubricated ball bearing motors for maintenance-free operation
- Automatic reset, thermal overload protection
- 120V, 60 Hz operation
- Steel housing with corrosion resistant finish
- Gripple fasteners supplied for safe mounting
- Rotating mounting bracket permits mounting at any angle
- Maximum permissible ambient temperature: 140 F
- Capacities up to 1,460 cfm
- Available in 10", 12" & 14" fan sizes

See Destratification Fan Application Guide for more information

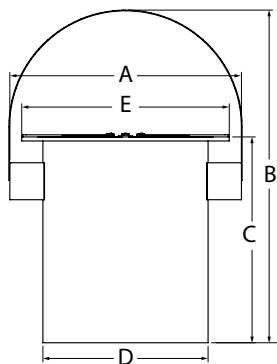

How Do I Determine How Many Fans I Need?

Air circulation should occur once or twice per hour to maintain a healthy building environment. Select the fan cfm based on the following ceiling height recommendations:

- 15 ft - 20 ft use 420 cfm fan or model DSF250
- 20 ft - 25 ft use 1055 cfm fan or model DSF300
- 25 ft - up use 1460 cfm fan or model DSF350

To determine the number of DSF fans for a given area, the following information is required:

- (L x W x H) = Size of room
- Size of room / cfm / 60 = Number of units

Example: a building is 125 ft long, 75 ft wide, and 20 ft high.

- $125 \times 75 \times 20 = 187,500$ cu. ft
- $187,500$ cu. ft / 1055 cfm (DSF300 Fan) / $60 = 3$ DSF Fans (round to the nearest whole number)

DIMENSIONS IN INCHES*

MODEL	A	B	C	D	E
DSF250	15.2	20.2	15.2	10.2	13.4
DSF300	17.3	23.9	17.9	12.2	15.4
DSF350	19.2	27.3	20.3	14.2	17.4

*DO NOT USE FOR CONSTRUCTION

FAN PERFORMANCE

MAX WATTS	MAX AMPS	RPM	CFM 0" SP	AIR VELOCITY DEPENDING ON DISTANCE FROM DSF FAN, FPM											
				3ft	6ft	10ft	13ft	15ft	20ft	23ft	25ft	30ft	33ft	35ft	
60	0.51	1700	420	378	270	220	156	90	60	20	-	-	-	-	
94	0.80	1675	1055	918	594	380	234	162	120	79	38	20	-	-	
162	1.38	1685	1460	1100	756	760	468	324	300	217	169	120	59	19	

CONSULT FACTORY FOR CERTIFIED PRINTS

CMX & DSF Fan Applications

Commercial

- Gymnasiums
- Showrooms
- Big box stores
- Schools

Industrial

- Warehouses
- Cold storage
- Distribution centers
- Airport hangars

Agriculture

- Dairy barns
- Greenhouses
- Horse stables
- Produce farms

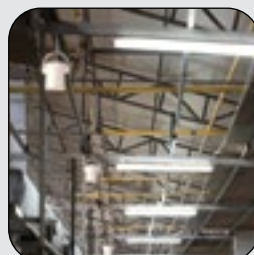

WALL FANS

SEF, GEF & PEF WALL FANS



SEF, GEF & PEF Wall Fans are ideal for through-the-wall general ventilation applications. They provide a compact, cost effective ventilation solution for factories, warehouses, equipment cooling, mechanical rooms, and more.

Features & Benefits

- Suitable for through-the-wall installation
- 2 or 3 speed operation, pull chain switch
- 120 VAC single phase 60 Hz operation
- UL/CSA approved motor
- Totally enclosed permanently lubricated motor
- External junction box
- Aluminum fan blades
- Galvanized frame (SEF model only)
- Painted steel panel (PEF model only)
- Plated steel spiral wire guard
- Mounts directly to inside wall
- Sizes: 10" to 30"
- Capacities to 3,950 cfm

Accessories / Options

- WS wall shutter for models PEF and GEF
 - Aluminum blades; galvanized steel frame

FAN SIZE	MTR HP	AMPS (HIGH)	AIRFLOW PERFORMANCE (CFM)		
			HIGH	MEDIUM	LOW
10	1/2	1.0	680	540	460
12	1/2	1.1	825	710	560
14	3/8	2.0	1520	1400	1250
16	3/8	2.1	2100	1900	1700
18	3/8	2.2	2300	2100	1850
20	1/4	2.3	2925	N/A	2380
24	1/4	2.5	3400	N/A	2770
30	1/4	2.7	3950	N/A	3080



SEF Shutter Mount Fans

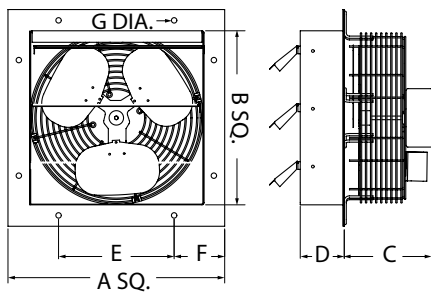

GEF Guard Mount Fans

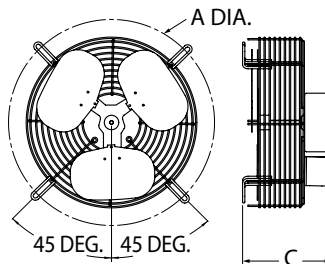

PEF Panel Mount Fans

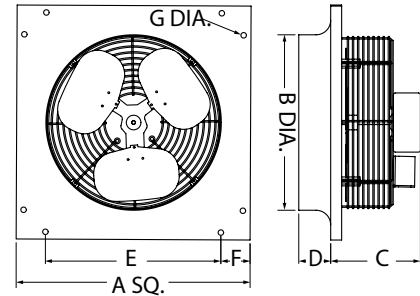

DIMENSIONS IN INCHES*

MODEL	A	B	C	D	E	F	G	WT (lbs)
SEF-10	13.0	10.1	6.1	2.5	6.0	3.5	0.3	11
SEF-12	15.0	12.1	7.1	2.5	8.0	3.5	0.3	16
SEF-14	17.0	14.1	7.9	2.5	10.0	3.5	0.3	17
SEF-16	19.0	16.1	7.9	2.5	12.0	3.5	0.3	18
SEF-18	21.0	18.1	7.6	2.5	14.0	3.5	0.3	25
SEF-20	23.0	20.1	9.4	2.5	16.0	3.5	0.3	34
SEF-24	27.0	24.1	9.9	2.5	20.0	3.5	0.3	47
SEF-30	33.0	30.1	9.9	3.0	26.0	3.5	0.3	54

DIMENSIONS IN INCHES*

MODEL	A	C	WT (lbs)
GEF-10	14.1	5.8	11
GEF-12	16.4	6.8	12
GEF-14	18.2	7.6	17
GEF-16	20.3	7.6	18
GEF-18	22.6	7.3	19
GEF-20	25.4	9.1	34
GEF-24	29.0	9.6	38
GEF-30	34.8	9.6	42

DIMENSIONS IN INCHES*

MODEL	A	B	C	D	E	F	G	WT (lbs)
PEF-10	12.5	10.3	6.1	1.0	3.8	4.4	0.3	11
PEF-12	14.5	12.3	7.1	1.0	5.8	4.4	0.3	17
PEF-14	17.0	14.3	7.9	1.5	8.3	4.4	0.3	17
PEF-16	19.0	16.3	7.9	1.9	10.3	4.4	0.3	18
PEF-18	21.0	18.1	7.6	1.8	12.3	4.4	0.3	26
PEF-20	23.0	20.3	9.4	1.8	14.3	4.4	0.3	34
PEF-24	28.0	24.3	9.9	2.5	18.3	4.4	0.3	48
PEF-30	34.0	30.3	9.9	2.5	24.3	4.4	0.3	55

*DO NOT USE FOR CONSTRUCTION

CONSULT FACTORY FOR CERTIFIED PRINTS

RMD DIRECT DRIVE AXIAL EXHAUST FANS

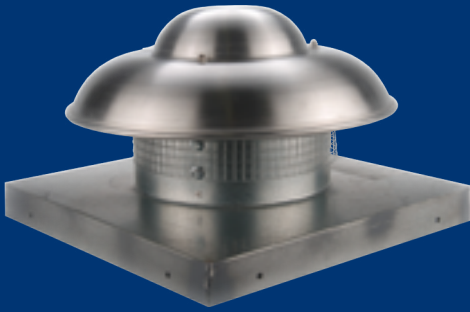

RMD Axial Exhaust Fans are suitable for roof or wall mounting in commercial ventilation applications such as mechanical room exhaust, warehouse exhaust and much more. They are the perfect low-cost choice for areas that have little or no ductwork.

Features & Benefits

- Suitable for roof or wall mounting
- Axial impellers constructed with die formed blades riveted to a steel hub
- Spun aluminum housing for weather-resistant durability
- Wire conduit provides a clear channel for electrical connections
- Bird screen
- Totally enclosed, permanently lubricated, ball bearing motor
- Disconnect switch
- 110 F max. temperature rating
- Available in 115V 1 phase
- Diameters range from 10" to 18"
- Direct drive capacities to 2,400 cfm

Accessories / Options

- Gravity dampers
- Motorized dampers
- Wall mount brackets
- Roof curb

MODEL	RPM	MTR HP	FLA	AIRFLOW PERFORMANCE (CFM)							
				0" SP	0.125" SP	0.25" SP	0.375" SP	0.50" SP	0.625" SP	0.75" SP	0.875" SP
RMD-10	1500	1/30	1.1	500	339	267	173	-	-	-	-
RMD-12	1500	1/10	1.2	830	710	620	522	436	357	270	-
RMD-14	1100	1/6	2.2	1160	899	786	646	521	384	236	-
RMD-18	1100	1/3	4.5	2400	2034	1628	1491	1293	1084	881	662

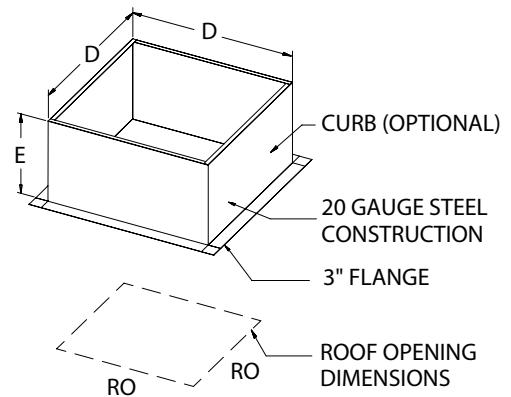
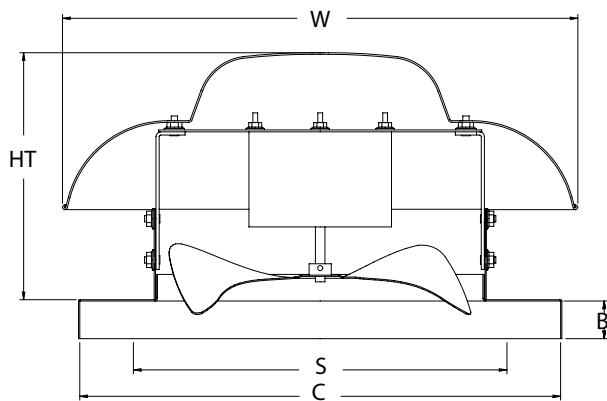

MODEL	DIMENSIONS IN INCHES*							WT (lbs)	DAMPER SQUARE	MANUFACTURE CODE
	HT	W	B	C	D	E	RO			
RMD-10	9.8	18.3	2	19	17.5	12	13	24	12	DDAR10
RMD-12	10.8	20.3	2	19	17.5	12	13	32	12	DDAR12
RMD-14	12.6	27.3	2	21	19.5	12	16	45	15	DDAR14
RMD-18	14.4	33.6	2	26	24.5	12	20	67	19	DDAR18

*DO NOT USE FOR CONSTRUCTION

CONSULT FACTORY FOR CERTIFIED PRINTS

ROOF & WALL EXHAUST FANS

CDD DIRECT DRIVE DOWNBLAST FANS



CDD Direct Drive Downblast Fans provide quiet operation, within a weather-resistant spun aluminum housing. These commercial / light industrial fans are ideal for applications in schools, hospitals, office buildings, and much more.

Features & Benefits

- Suitable for roof or wall mount
- Backward inclined, non-overloading wheels
- Spun aluminum housing for weather-resistant durability
- Wire conduit provides protected channel for electrical connections
- Blades and inlets fabricated from aluminum
- Bird screen
- Disconnect switch
- Variable speed control
- 110 F max. temperature rating
- Available in 115V 1 phase, contact factory for EC motors
- Direct drive capacities to 3,300 cfm

Accessories / Options

- Gravity dampers
- Motorized dampers
- Wall mount brackets
- Roof curb

CDD Performance

- See page 34

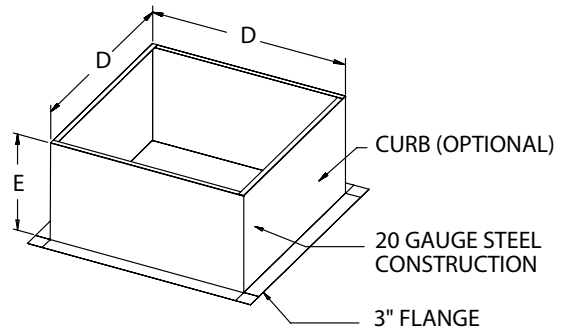
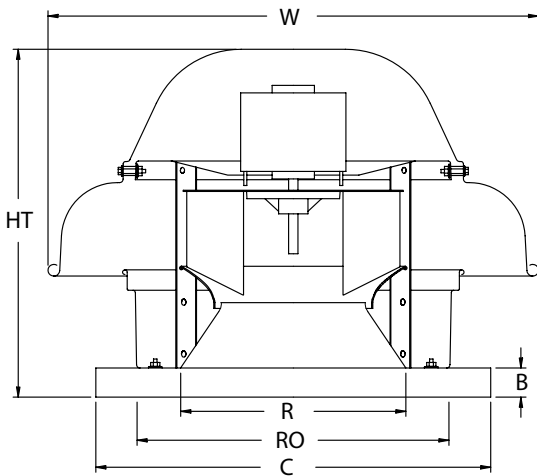

MODEL	DIMENSIONS IN INCHES*								WT (lbs)	DAMPER SQUARE	MANUFACTURE CODE
	HT	W	B	C	D	E	R	RO			
CDD-10	14.5	20.8	2	19.0	17.5	12	8.1	13	30	12	DR10H
CDD-12	16.3	23.8	2	19.0	17.5	12	10.6	13	35	12	DR12H
CDD-30	19.1	26.3	2	21.0	19.5	12	12.1	16	45	15	DR30H
CDD-33	19.1	26.3	2	21.0	19.5	12	12.1	16	45	15	DR33H
CDD-50	21.8	29.8	2	21.0	19.5	12	13.3	16	50	15	DR50H
CDD-85	23.4	33.3	2	24.8	23.0	12	14.9	20	60	19	DR85H

*DO NOT USE FOR CONSTRUCTION

CONSULT FACTORY FOR CERTIFIED PRINTS

CUD DIRECT DRIVE UPBLAST FANS



CUD Direct Drive Upblast Exhaust Fans are designed to discharge contaminated exhaust air away from roof surfaces and building walls. Available in UL762 Restaurant Exhaust Kits, CUD fans are suitable for commercial range hood exhaust and much more.

Features & Benefits

- Suitable for roof or wall mount
- Backward inclined, non-overloading wheels
- Spun aluminum housing for weather-resistant durability
- Fully enclosed drive compartment protects motor from airborne contaminants
- Fully ventilated motor cooling compartment for long motor life
- Quick release latches for easy access to motor compartment
- Blades and inlets fabricated from aluminum
- Variable speed control (standard on single phase units only)
- Disconnect switch
- Fully welded leak-proof grease drain (except for model CUD-10)
- 300 F max. temperature rating (except for model CUD-10)
- Available in 115V 1 phase, contact factory for EC motors

Accessories / Options

- Gravity and motorized dampers
- Wall mount brackets
- Roof curb (vented or non-vented)
- Bird screen

Restaurant Exhaust Kits (UL762)

Kits include the following:

- Grease cup
- Grease pipe
- Down spout
- Hinge kit

Note: Restaurant exhaust (UL762) requires the use of a vented roof curb. Select 20" high roof curbs are available.

CUD Performance

- See page 34

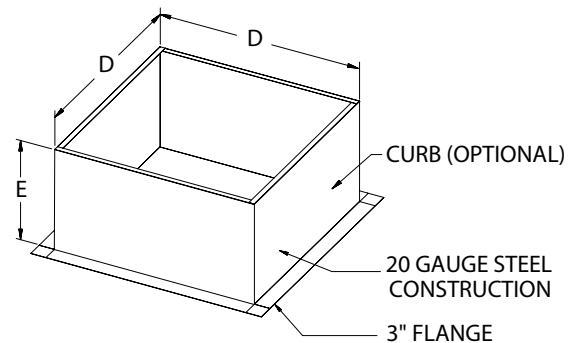
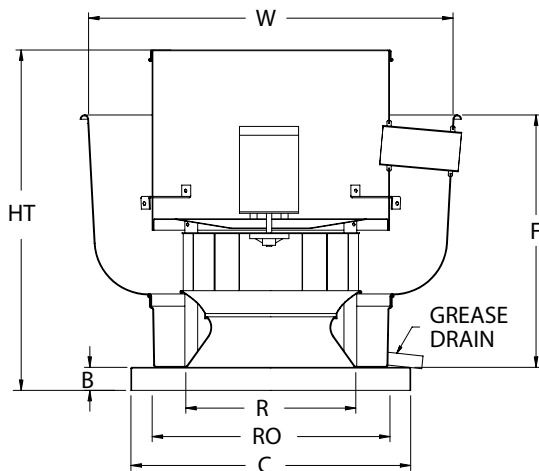

DIMENSIONS IN INCHES*

MODEL	HT	W	B	C	D	E	F	R	RO	WT (lbs)	DAMPER SQUARE	MANUFACTURE CODE
CUD-10	14.5	17.8	2	19.0	17.5	12	9.5	8.1	13	30	12	DU10H
CUD-12	18.0	22.0	2	19.0	17.5	12	14.5	10.6	13	40	12	DU12H
CUD-30	25.3	25.5	2	21.0	19.5	12	18.5	12.1	16	50	15	DU30H
CUD-33	25.3	25.5	2	21.0	19.5	12	18.5	12.1	16	50	15	DU33H
CUD-50	27.3	28.9	2	21.0	19.5	12	21.5	13.3	16	55	15	DU50H
CUD-85	30.5	31.9	2	24.8	23.0	12	23.0	14.9	20	60	19	DU85H

*DO NOT USE FOR CONSTRUCTION

CONSULT FACTORY FOR CERTIFIED PRINTS

ROOF & WALL EXHAUST FANS

CDD Direct Drive Downblast Fans

PERFORMANCE																														
MODEL	CFM	0" SP		0.125" SP		0.25" SP		0.375" SP		0.50" SP		0.625" SP		0.75" SP		0.875" SP		1.00" SP		1.125" SP		1.25" SP		1.5" SP		1.75" SP				
		RPM	BHP	RPM	BHP	RPM	BHP	RPM	BHP	RPM	BHP	RPM	BHP	RPM	BHP	RPM	BHP	RPM	BHP	RPM	BHP	RPM	BHP	RPM	BHP	RPM	BHP	RPM	BHP	
CDD-10	250	786	0.01	1008	0.02	1196	0.03	1374	0.05	1534	0.07																			
	350	1097	0.03	1268	0.04	1417	0.06	1556	0.07																					
	450	1411	0.06	1546	0.07																									
CDD-12	400	639	0.01	839	0.03	1000	0.04	1143	0.07	1266	0.09	1384	0.12	1493	0.15	1594	0.18													
	600	957	0.04	1101	0.06	1230	0.08	1345	0.11	1449	0.14	1550	0.17																	
	800	1274	0.09	1384	0.12	1490	0.15	1587	0.18																					
	1000	1592	0.18																											
CDD-30	800	926	0.05	1051	0.07	1163	0.09	1258	0.12	1345	0.14	1423	0.17	1495	0.19	1566	0.22													
	1000	1157	0.09	1259	0.12	1355	0.14	1443	0.17	1522	0.20	1595	0.24																	
	1200	1389	0.16	1474	0.19	1556	0.22																							
	1400	1618	0.25																											
CDD-33	600	731	0.03	882	0.05	1014	0.07	1124	0.10	1220	0.12	1307	0.15	1389	0.18	1467	0.22	1538	0.25	1609	0.29	1676	0.32							
	800	974	0.06	1088	0.09	1201	0.12	1301	0.15	1391	0.19	1473	0.22	1547	0.26	1619	0.29	1688	0.33											
	1000	1217	0.12	1307	0.15	1401	0.19	1490	0.23	1572	0.27	1650	0.31																	
	1200	1460	0.21	1535	0.25	1613	0.29	1690	0.33																					
CDD-50	1000	666	0.03	792	0.06	895	0.08	986	0.11	1068	0.14	1144	0.17	1214	0.21	1282	0.25	1346	0.28	1406	0.32	1464	0.37							
	1400	931	0.09	1026	0.13	1112	0.16	1188	0.20	1259	0.23	1325	0.27	1388	0.31	1448	0.35	1504	0.40	1559	0.44	1611	0.49							
	1800	1197	0.20	1273	0.24	1344	0.28	1410	0.33	1472	0.37	1531	0.42	1586	0.46															
	2200	1463	0.36	1524	0.41	1586	0.46																							
CDD-85	1500	705	0.06		893	0.13		1038	0.20		1161	0.29		1271	0.38		1372	0.47	1466	0.58	1556	0.69								
	1900	892	0.13		1049	0.21		1180	0.30		1293	0.39		1394	0.50		1488	0.60	1575	0.71										
	2300	1080	0.23		1212	0.33		1331	0.43		1436	0.54		1529	0.65															
	2700	1268	0.37		1382	0.48		1488	0.60		1585	0.73																		
	3100	1455	0.56		1555	0.69																								

CUD Direct Drive Upblast Fans

PERFORMANCE																												
MODEL	CFM	0" SP		0.125" SP		0.250" SP		0.375" SP		0.50" SP		0.625" SP		0.750" SP		0.875" SP		1" SP		1.250" SP		1.50" SP		1.750" SP		2.00" SP		
		RPM	BHP	RPM	BHP	RPM	BHP	RPM	BHP	RPM	BHP	RPM	BHP	RPM	BHP	RPM	BHP	RPM	BHP	RPM	BHP	RPM	BHP	RPM	BHP	RPM	BHP	RPM
CUD-10	250	755	0.01	969	0.02	1152	0.03	1309	0.04	1453	0.06	1582	0.08															
	300	906	0.01	1091	0.03	1255	0.04	1402	0.06	1531	0.07																	
	400	1205	0.04	1351	0.05	1481	0.07	1606	0.08																			
	500	1506	0.07																									
CUD-12	300	509	0.01	746	0.02	940	0.04	1103	0.06	1245	0.08	1370	0.11	1478	0.14	1587	0.18											
	500	846	0.03	1002	0.04	1142	0.07	1272	0.09	1393	0.12	1511	0.15	1613	0.18													
	700	1184	0.07	1304	0.10	1408	0.12	1509	0.15	1606	0.18																	
	900	1520	0.15																									
CUD-30	850	1071	0.05		1239	0.09		1396	0.14		1543	0.19																
	1050	1321	0.10		1460	0.15		1593	0.20																			
	1250	1572	0.17																									
CUD-33	700	857	0.04	974	0.06	1094	0.09	1199	0.12	1292	0.15	1375	0.18	1452	0.21	1525	0.24	1595	0.28									
	900	1102	0.09	1189	0.11	1286	0.14	1380	0.18	1466	0.21	1544	0.25	1619	0.29													
	1100	1346	0.17	1416	0.19	1493	0.23	1574	0.27																			
	1300	1591	0.27																									
CUD-50	1200	915	0.09		1117	0.16		1277	0.24		1418	0.32		1548	0.42													
	1500	1143	0.17		1315	0.26		1455	0.35		1582	0.45																
	1800	1372	0.29		1519	0.40																						
	2100	1601	0.46																									
CUD-85	1200	582	0.04		773	0.09		917	0.15		1041	0.22		1152	0.30	1254	0.39	1348	0.49	1435	0.59	1517	0.69					
	1600	776	0.09		928	0.16		1057	0.23		1167	0.32		1267	0.40	1359	0.50	1445	0.60	1527	0.71							
	2000	969	0.18		1093	0.26		1208	0.35		1309	0.45		1401	0.55	1485	0.65											
	2400	1163	0.31		1266	0.40		1368	0.51		1461	0.62		1545	0.73													
	2800	1357	0.50		1445	0.60		1533	0.72																			
	3200	1550	0.74																									

OEM AND INDUSTRIAL FANS & BLOWERS

Continental Fan also offers a vast array of OEM and Industrial Fans and Blowers. A small sampling is shown below.

APK DIRECT DRIVE PANEL FANS

APK Direct Drive Panel Fans are the ideal solution for applications that require high efficiency and quiet operation. These panel fans deliver maintenance-free performance at an affordable price.

- Spark resistant, cast aluminum airfoil axial impeller
- Superior performance and sound characteristics
- Baked polyester powder coat finish
- GRP (polypropylene) blades available
- All-aluminum design available
- Custom designs available from 12" to 36"
- Capacities to 23,000 cfm from stock components



AFK DIRECT DRIVE FLANGE FANS

AFK Direct Drive Flange Fans deliver maximum performance in minimal space. A fully reversible double flange design provides exceptional strength and allows for duct mounting if needed.

- Spark resistant, cast aluminum airfoil axial impeller
- Superior performance and sound characteristics
- Baked polyester powder coat finish
- GRP (polypropylene) blades available
- Fully reversible design option available
- Sizes range from 12" to 42"
- Capacities to 34,000 cfm from stock components



TCD BC AIRFOIL BLOWERS

TCD BC Airfoil Blowers are precision balanced air-moving devices that feature superior performance and exceptional smoothness. Combined with high efficiency TEFC motors, TCD blowers set new standards for efficiency and sound.

- Direct drive, non-overloading 'TEK' impeller
- Highly efficient airfoil (BCA) design
- Epoxy coated steel housing
- Rugged GRP (polyamide) impeller
- Cast aluminum impeller hub w/bushing
- CW rotation; rotatable to 5 positions
- Capacities to 4,500 cfm



AID DIRECT DRIVE AXIAL IN-LINE FANS

AID Axial In-Line Fans offer the perfect solution where high efficiency and quiet operation are required. Commonly used to move large volumes of air at medium and high pressures, AID fans utilize ELTA airfoil adjustable pitch impellers to maximize performance.

- NEMA 4 junction box, pre-wired and mounted on fan
- Spark resistant, cast aluminum airfoil axial impeller
- Baked polyester powder coat finish
- GRP (polypropylene) impeller available
- Fully reversible airflow option
- Sizes range from 12" to 27"
- Capacities to 11,400 cfm





**OEM Solutions
& Custom Fans**



**Industrial Fans
& Blowers**

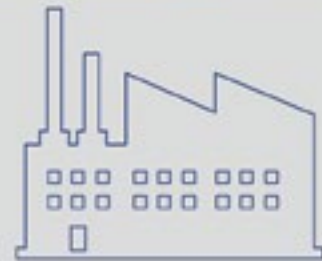

**Commercial Fans
& Dampers**



**Residential Fans &
Air Purifiers**



Wholesale Ventilation Products

Continental Fan Manufacturing Inc.
Buffalo, NY ~ Dayton, OH

Continental Fan Canada Inc.
Mississauga, ON

www.continentalfan.com
1-800-779-4021

Distributed by:

